

## LED Solutions

High Brightness LEDs, Indicators and Displays

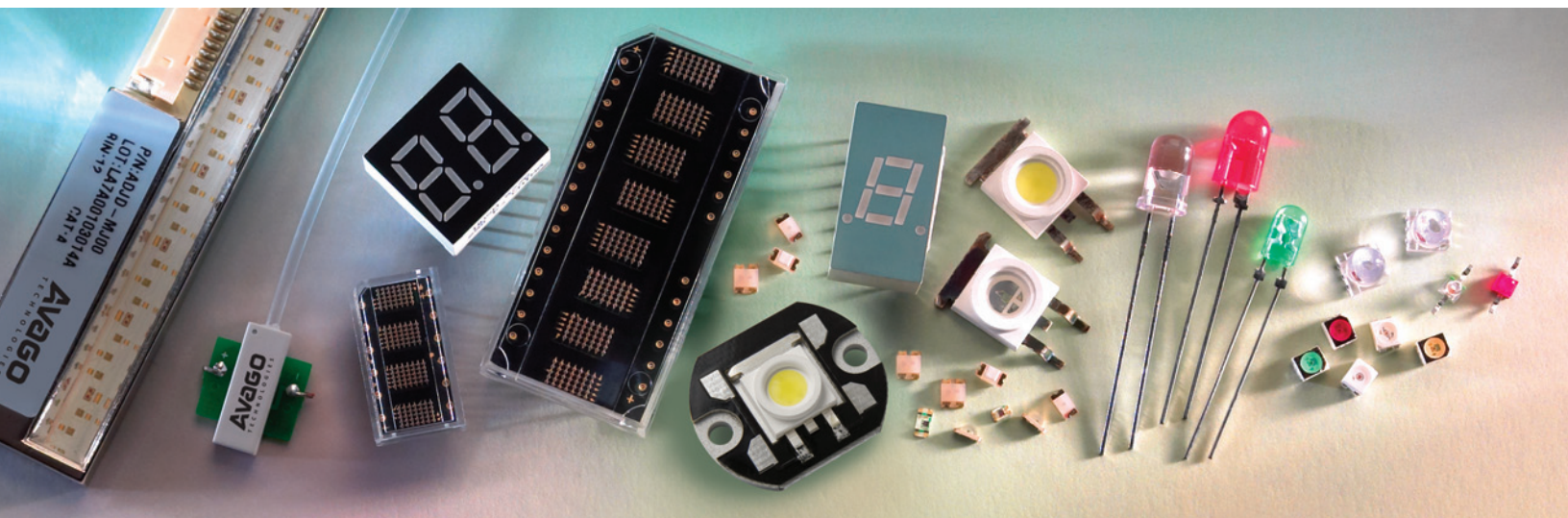

## Selection Guide

Your Imagination, Our Innovation  
*Sense • Illuminate • Connect*

## LED Solutions

### High Brightness LEDs

- 2 High Brightness Through-hole Lamps
- 12 Surface Mount PLCC LEDs
- 24 Envisium™ Surface Mount Power PLCC-4 LEDs
- 28 Moonstone™ High Power LEDs
- 34 Moonstone™ High Power RGB LED Modules

### LED Indicators and Displays

- 36 Standard Through-hole Lamps
- 41 Subminiature Lamps
- 45 Surface Mount ChipLEDs
- 53 Auto Focus Auxiliary Flash LEDs
- 55 Flexible Light Strip Modules
- 57 Seven-Segment Displays
- 84 Light Bars and Bar Graph Arrays
- 88 Smart Displays

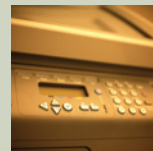

# Avago Technologies is one of the largest producers of visible light-emitting diodes in the world.

Avago Technologies offers “one-stop shopping” with its wide array of LED (Light Emitting Diodes) Solutions. With our large manufacturing base and many years of experience from our HP and Agilent days, we are one of the largest producers of visible LEDs in the world and ships billions of products annually.

Avago employs the latest in material and process technology to produce superior LEDs. Our highly acclaimed AlInGaP (aluminium indium gallium phosphide) LED material offers high brightness and stable light output over thousands of hours with excellent mean-time-before-failure (MTBF). With our cutting edge LED technology, our solution also offers dazzling blue and green colors with InGaN (indium gallium nitride) material, and very cost-effective GaP (gallium phosphide) based technology, perfect for low to moderate light output. Avago’s LEDs create brilliant lights with rich life-like colors for our customers’ applications which are longer lasting and at a globally competitive price. They are suitable for almost any applications that customers need today with wide selection of viewing and package options.

Key products include from high brightness and high power LEDs, PLCC surface-mount LEDs, to standard through-hole lamps, surface-mount LEDs, flash LEDs, flexible light strip modules, and various LED displays. These LED Solutions address a wide range of markets, including electronic sign and signal, automotive, solid-state lighting, consumer electronics, home and mobile appliances.

For virtually all established and emerging applications, Avago Technologies has the right LED Solutions to meet your design requirements.





## High Brightness Through-hole Lamps

### Description

Avago Technologies offers two types of technology-based LEDs. AllnGaP and InGaN product offerings are suitable for high brightness needs. Through-hole LEDs are offered in a variety of packages such as 3 mm, 4 mm and 5 mm.

These devices are casted from advanced optical grade epoxy, which provides superior high temperature performance and excellent moisture resistance.

Through-hole LEDs are suitable for all applications requiring backlighting and status indication. Manufacturers of signs and message panels as well as consumer electronics and automotive interiors use LEDs to add value to their products. Low power consumption, high reliability and a broad range of colors and packages are just a few reasons why.

### Features and Benefits

- Excellent product quality and reliability
- Wide range of products
- Competitive pricing
- Wide operating temperature range
  - With minor electrical/optical changes
- Lower power consumption
  - High efficiency, low drive currents and low driving voltages required
- High reliability
  - No replacement for life of equipment
- High reliability for AllnGaP lamps compared to TS AlGaAs at equivalent pricing and high brightness
  - No replacement for life of equipment with 100 or 1000 hours projected life
- Thin, light weight and robust packaging
  - Excellent performance even under vibration and mechanical shock
- Four colors available with high luminous intensity in AllnGaP LED lamps
  - Amber (590 nm), Red (626 nm), Orange (605 nm) and Red-Orange (615 nm)
- Four colors available with high luminous intensity in InGaN LED lamps
  - Blue (470 nm), Green (527 nm), Cyan (505 nm) and White
- Several packaging options
  - Different sizes with a clear or diffused lens and different spatial radiation patterns available in bulk and ammo-pack

### Typical Applications

All applications requiring back lighting and status indications in:

- Electronic Signs and Signals
  - road safety signs
  - exit signs
  - moving message panels
  - static message displays
  - full color signs
  - traffic signals
- Consumer
  - gaming and vending machines
- Automotive and Other
  - automotive interior
  - exercise equipment
  - medical equipment
  - front panel industrial equipment

## High Brightness Lamps

Part Number	Color	Dominant Wavelength (nm)	Viewing Angle	Standoff Leads	Luminous Intensity Iv (cd) @ 20 mA		Leadframe Orientation	Package Drawing
					Min.	Max.		
<b>5mm Round LED Lamps</b>								
<b>8° Viewing Angle</b>								
HLMP-EL08-X1000	Amber	590	8°	No	7200	21000		
HLMP-EL10-X1000	Amber	590	8°	Yes	7200	21000		
HLMP-EJ08-X1000	Orange	605	8°	No	7200	21000		
HLMP-EJ10-X1000	Orange	605	8°	Yes	7200	21000		
HLMP-EH08-Y2000	Red Orange	615	8°	No	9300	27000		
HLMP-EH10-Y2000	Red Orange	615	8°	Yes	9300	27000		
HLMP-EG08-X1000	Red	626	8°	No	7200	21000		
HLMP-EG10-X1000	Red	626	8°	Yes	7200	21000		
<b>5mm Round LED Lamps</b>								
<b>15° Viewing Angle</b>								
HLMP-EL12-VY0DD	Amber	590	15°	No	4200	12000		
HLMP-EL13-VY0DD	Amber	590	15°	Yes	4200	12000		
HLMP-EH12-VY0DD	Red Orange	615	15°	No	4200	12000		
HLMP-EH13-VY0DD	Red Orange	615	15°	Yes	4200	12000		
HLMP-EG12-VY0DD	Red	626	15°	No	3200	7200		
HLMP-EG13-VY0DD	Red	626	15°	Yes	4200	12000		
HLMP-CB13-UX0DD	Blue	470	15°	No	3200	9300		
HLMP-CB14-UX0DD	Blue	470	15°	Yes	3200	9300		
HLMP-CM13-Z30DD	Green	525	15°	No	12000	35000		
HLMP-CM14-Z30DD	Green	525	15°	Yes	12000	35000		
<b>5mm Round LED Lamps</b>								
<b>23° Viewing Angle</b>								
HLMP-EL22-UX0DD	Amber	590	23°	No	3200	9300		
HLMP-EL23-UX0DD	Amber	590	23°	Yes	3200	9300		
HLMP-EH22-TW0DD	Red Orange	615	23°	No	2500	7200		
HLMP-EH23-TW0DD	Red Orange	615	23°	Yes	2500	7200		
HLMP-EG22-UX0DD	Red	626	23°	No	3200	9300		
HLMP-EG23-UX0DD	Red	626	23°	Yes	4200	7200		
HLMP-CB22-SV0DD	Blue	470	23°	No	1900	5500		
HLMP-CB25-SV0DD	Blue	470	23°	Yes	1900	5500		
HLMP-CM22-X10DD	Green	525	23°	No	7200	21000		
HLMP-CM25-X10DD	Green	525	23°	Yes	7200	21000		

# LED Solutions

## High Brightness Lamps

Part Number	Color	Dominant Wavelength (nm)	Viewing Angle	Standoff Leads	Luminous Intensity Iv (cd) @ 20 mA		Leadframe Orientation	Package Drawing
					Min.	Max.		
<b>5mm Round LED Lamps</b>								
<b>30° Viewing Angle</b>								
HLMP-EL35-TW0DD	Amber	590	30°	No	2500	7200		
HLMP-EL37-TW0DD	Amber	590	30°	Yes	2500	7200		
HLMP-EH35-SV0DD	Red Orange	615	30°	No	1900	5500		
HLMP-EH37-SV0DD	Red Orange	615	30°	Yes	1900	5500		
HLMP-EG35-TW0DD	Red	626	30°	No	2500	7200		
HLMP-EG37-TW0DD	Red	626	30°	Yes	3200	5500		
HLMP-CB34-RU0DD	Blue	470	30°	No	1500	4200		
HLMP-CB35-RU0DD	Blue	470	30°	Yes	1500	4200		
HLMP-CM34-WZ0DD	Green	525	30°	No	5500	16000		
HLMP-CM35-WZ0DD	Green	525	30°	Yes	5500	16000		
<b>4mm Standard Oval LED Lamps</b>								
<b>50° x 100° Viewing Angle</b>								
HLMP-LG63-TX0ZZ	Red	626	50° x 100°	Yes	800	1990	Parallel	A
HLMP-LM65-Z30ZZ	Green	525	50° x 100°	Yes	2400	5040	Parallel	A
HLMP-LB65-RU0ZZ	Blue	470	50° x 100°	Yes	550	1150	Parallel	A
<b>4mm Super Oval LED Lamps</b>								
<b>60° x 120° Viewing Angle</b>								
HLMP-RL10-MP0DD	Amber	590	60° x 120°	Yes	520	1150	Parallel	C
HLMP-SL10-MP0DD	Amber	590	60° x 120°	Yes	520	1150	Perpendicular	B
HLMP-RG10-JM000	Red	626	60° x 120°	Yes	240	680	Parallel	C
HLMP-SG10-JM000	Red	626	60° x 120°	Yes	240	680	Perpendicular	B
<b>5mm Standard Oval LED Lamps</b>								
<b>40° x 100° Viewing Angle</b>								
HLMP-HL62-TX0DD	Amber	590	40° x 100°	No	800	1990	Parallel	D
HLMP-HL63-TX0DD	Amber	590	40° x 100°	Yes	800	1990	Parallel	E
HLMP-HH62-TX0DD	Red Orange	615	40° x 100°	No	800	1990	Parallel	D
HLMP-HH63-TX0DD	Red Orange	615	40° x 100°	Yes	800	1990	Parallel	E
HLMP-HG62-TX0DD	Red	626	40° x 100°	No	800	1990	Parallel	D
HLMP-HG63-TX0DD	Red	626	40° x 100°	Yes	800	1990	Parallel	E
HLMP-HG63-TX0ZZ	Red	626	40° x 100°	Yes	800	1990	Parallel	E
HLMP-HM65-Y30ZZ	Green	525	40° x 100°	Yes	1990	5040	Parallel	E
HLMP-HB65-QU0ZZ	Blue	470	40° x 100°	Yes	460	1150	Parallel	E

# LED Solutions

## High Brightness Lamps

Part Number	Color	Dominant Wavelength (nm)	Viewing Angle	Standoff Leads	Luminous Intensity Iv (cd) @ 20 mA		Leadframe Orientation	Package Drawing
					Min.	Max.		
<b>5mm Mini Oval LED Lamps</b>								
<b>30° x 70° Viewing Angle</b>								
HLMP-AL62-UX0DD	Amber	590	30° x70°	No	960	1990	Parallel	F
HLMP-AL63-UX0DD	Amber	590	30° x70°	Yes	960	1990	Parallel	G
HLMP-AH62-UX0DD	Red Orange	615	30° x70°	No	960	1990	Parallel	F
HLMP-AH63-UX0DD	Red Orange	615	30° x70°	Yes	960	1990	Parallel	G
HLMP-AG62-UX0DD	Red	626	30° x70°	No	960	1990	Parallel	F
HLMP-AG63-UX0DD	Red	626	30° x70°	Yes	960	1990	Parallel	G
<b>White 5mm Round LED</b>								
HLMP-CW11-X1000	Cold White	0.31,0.31	15°	No	7200	21000		
HLMP-CW12-X1000	Cold White	0.31,0.31	15°	Yes	7200	21000		
HLMP-CW15-VY000	Cold White	0.31,0.31	15°	No	4200	12000		
HLMP-CW16-VY000	Cold White	0.31,0.31	15°	Yes	4200	12000		
HLMP-CW26-VY000	Cold White	0.31,0.31	23°	No	4200	12000		
HLMP-CW27-VY000	Cold White	0.31,0.31	23°	Yes	4200	12000		
HLMP-CW36-UX000	Cold White	0.31,0.31	30°	No	3200	9300		
HLMP-CW37-UX000	Cold White	0.31,0.31	30°	Yes	3200	9300		
HLMP-CW46-RU000	Cold White	0.31,0.31	50°	No	1500	4200		
HLMP-CW47-RU000	Cold White	0.31,0.31	50°	Yes	1500	4200		
HLMP-CW76-QT000	Cold White	0.31,0.31	70°	No	1150	3200		
HLMP-CW77-QT000	Cold White	0.31,0.31	70°	Yes	1150	3200		

# LED Solutions

## High Brightness Lamps

### High Brightness LED Lamps 1.3:1 Intensity Bin Limits (mcd at 20mA)

Bin Name	Min.	Max.
D	65	85
E	85	110
F	110	140
G	140	180
H	180	240
J	240	310
K	310	400
L	400	520
M	520	680
N	680	880
P	880	1150
Q	1150	1500
R	1500	1900
S	1900	2500
T	2500	3200
U	3200	4200
V	4200	5500
W	5500	7200
X	7200	9300
Y	9300	12000
Z	12000	16000
1	16000	21000
2	21000	27000
3	27000	35000
4	35000	45000
5	45000	59000
6	59000	76000

Tolerance for each bin limit is  $\pm 15\%$

### High Brightness LED Lamps 1.2:1 Intensity Bin Limits (mcd at 20mA)

Bin Name	Min.	Max.
P	380	460
Q	460	550
R	550	660
S	660	800
T	800	960
U	960	1150
V	1150	1380
W	1380	1660
X	1660	1990
Y	1990	2400
Z	2400	2900
1	2900	3500
2	3500	4200
3	4200	5040
4	5040	6050
5	6050	7260
6	7260	8710
7	8710	10460
8	10460	12560
9	12560	15100

### White Color Bin Limit Tables

Rank		Limits (Chromaticity Coordinates)			
1	x	0.330	0.330	0.356	0.361
	y	0.360	0.318	0.351	0.385
2	x	0.287	0.296	0.330	0.330
	y	0.295	0.276	0.318	0.339
3	x	0.264	0.280	0.296	0.283
	y	0.267	0.248	0.276	0.305
4	x	0.283	0.287	0.330	0.330
	y	0.305	0.295	0.339	0.360

Tolerance for each bin limit is  $\pm 0.01$

### Color Bin Structure

Bin ID	nm @ 20 mA	
Orange	Min.	Max.
2	599.5	604.5
4	604.5	610.5

Tolerance for each bin limit is  $\pm 0.5$  nm

Red	Min.	Max.
Category 1	618.0	628.0
Category 2	620.0	630.0

Note: There are two categories of wavelength. Please refer to individual datasheet for details

Tolerance for each bin limit is  $\pm 0.5$ nm

Red Orange	Min.	Max.
Full Distribution	612	621.7

Tolerance for each bin limit is  $\pm 0.5$  nm

These intensity and color charts show the various binning information for Precision Optical Performance AlInGaP LEDs. Red and reddish orange devices are not color binned as eyes are less sensitive to wavelength shifts in these color regions.

### Color Bin Structure

Bin ID	nm @ 20 mA	
Blue	Min.	Max.
1	460	464
2	464	468
3	468	472
4	472	476
5	476	480

Tolerance for each bin limit is  $\pm 0.5$  nm

Green	Min.	Max.
1	520	524
2	524	528
3	528	532
4	532	536
5	536	540

Tolerance for each bin limit is  $\pm 0.5$  nm

Amber	Min.	Max.
1	584.5	587.0
2	587.0	589.5
4	589.5	592.0
6	592.0	594.5

Tolerance for each bin limit is  $\pm 0.5$  nm

# LED Solutions

## High Brightness Lamps

### 5 mm (T1 3/4) LED Lamps Package

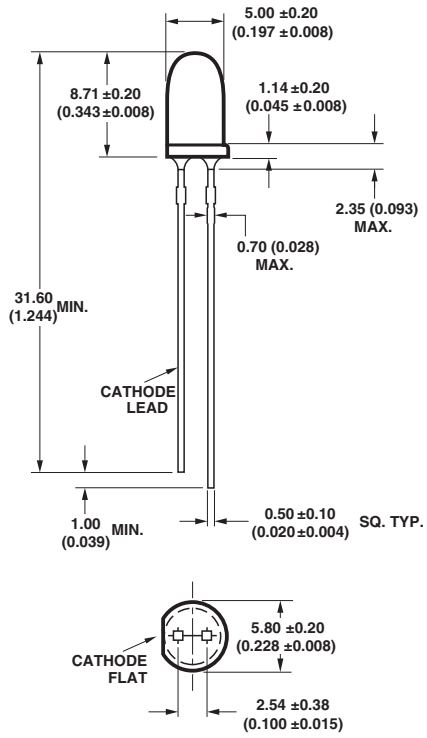

# LED Solutions

## 4 mm Standard Oval LED Lamps 50° x 100° Viewing Angle

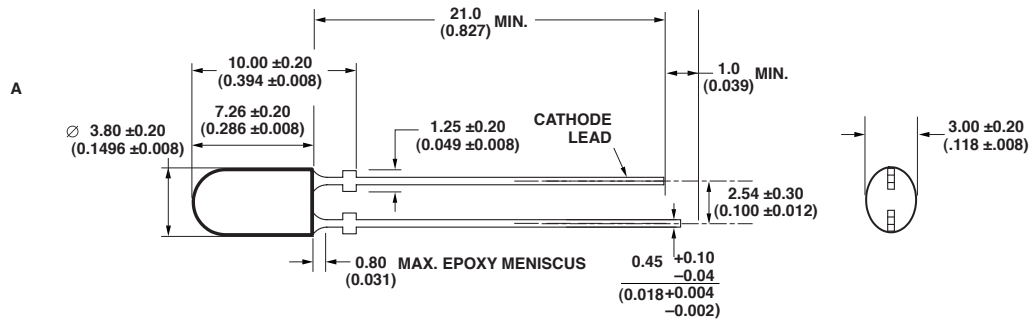

## 4 mm Super Oval LED Lamps 60° x 120° Viewing Angle

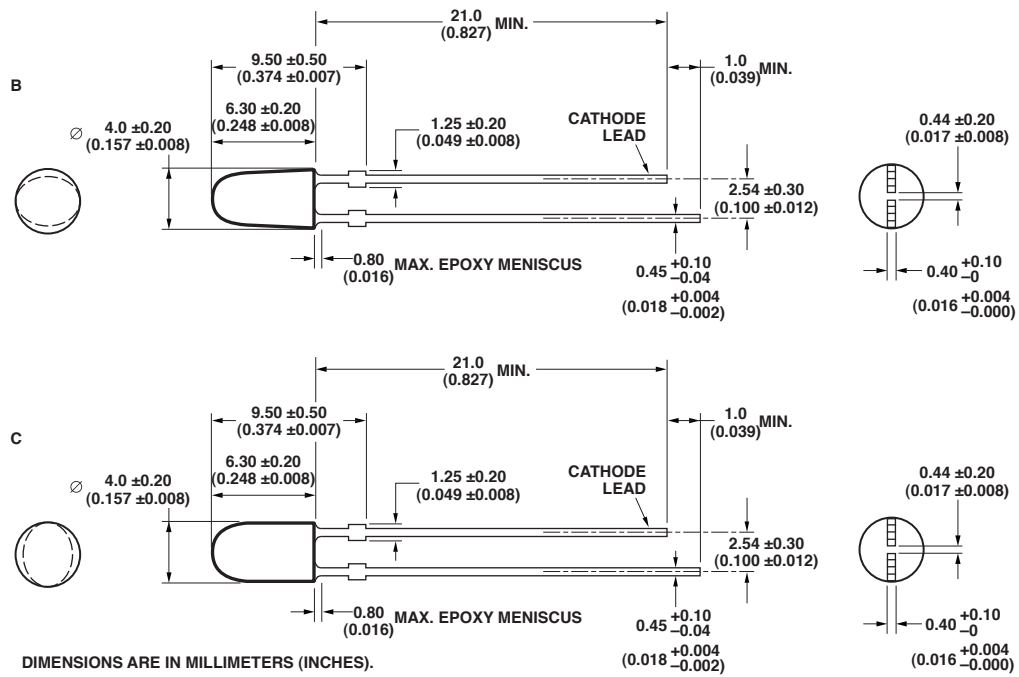

# LED Solutions

## 5 mm Standard Oval LED Lamps 40° x 100° Viewing Angle

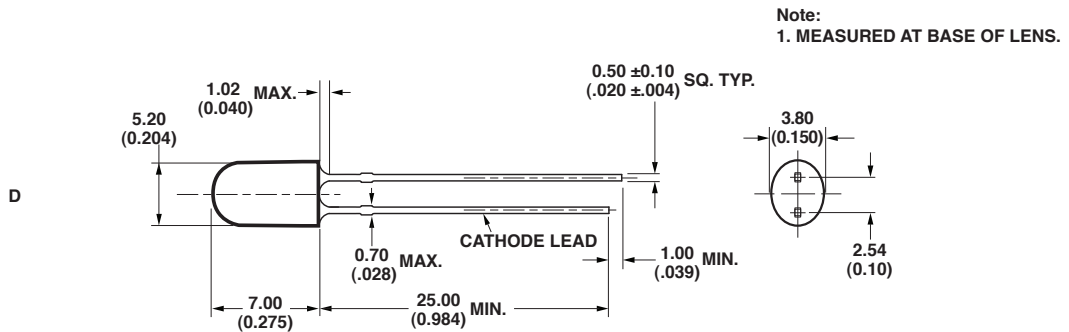

DIMENSIONS ARE IN MILLIMETERS (INCHES)

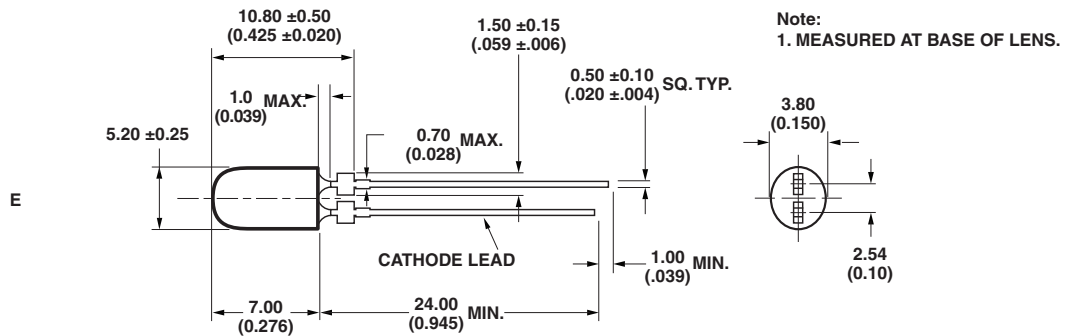

DIMENSIONS ARE IN MILLIMETERS (INCHES)  
TOLERANCE IS ± 0.20MM UNLESS OTHER SPECIFIED

# LED Solutions

## 5mm Mini Oval LED Lamps 30° x 70° Viewing Angle

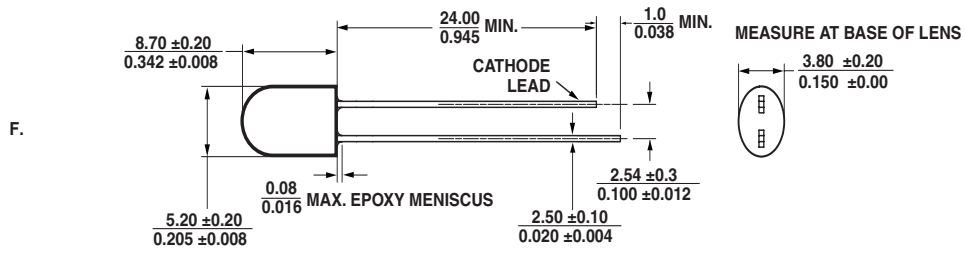

DIMENSIONS ARE IN MILLIMETERS (INCHES)

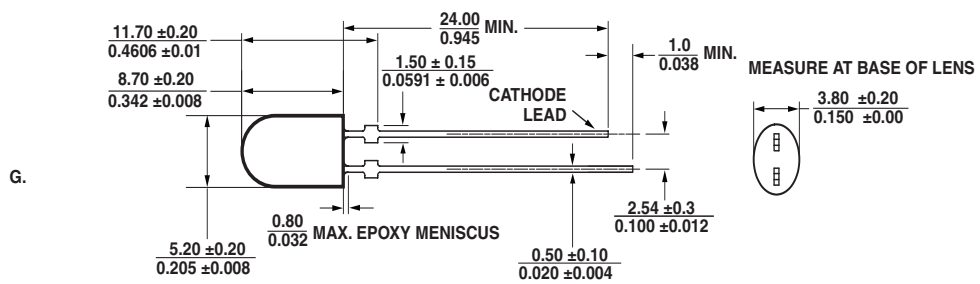

DIMENSIONS ARE IN MILLIMETERS (INCHES)  
TOLERANCE IS ± 0.02mm UNLESS OTHERWISE SPECIFIED



## Surface Mount PLCC LEDs

### Description

This surface-mount LED comes in PLCC standard package dimension. It has a substrate made up of a molded plastic reflector sitting on top of a bent lead frame. The die is attached within the reflector cavity and the cavity is encapsulated by an Avago Technologies proprietary epoxy blend.

The PLCC SMT LED products with a viewing angle of 120° is ideal for instruments/switch/icon backlighting. With additional lens in 30° variants, these products are especially fitting to applications for traffic lights, CHMSL and displays. Its external reflector makes easy coupling with light pipe/light guide for an even-larger area backlighting. The package design coupled with careful selection of component materials allow these products to perform with high reliability in a larger temperature range -40°C to 100°C. The high reliability feature is crucial to Automotive Interior and Indoor ESS.

This package is also designed to be compatible with both IR-solder reflow and through-the-wave soldering.

### Features and Benefits

- Industry Standard PLCC SMT package
  - No change in existing board layout, drop-in replacement for the existing PLCC SMT LEDs
- High brightness using AlInGaP and InGaN dice technologies
- Available in multiple colors
  - Broad range of colors: Red, Red-Orange, Orange, Amber, Yellow-Green, Emerald Green, Green, Cyan, Blue and White
- Available in viewing angle of 30° and 120°
  - Well-suited for backlighting applications
- High volume, high reliability
  - Cost-effective solution
- Compatible with both IR and TTW soldering process
- Black reflector surface option for reduce contrast in ESS
- High brightness performance – only PLCC SMT LED supplier offering TS AlInGaP material

### Special Product Features/Benefits

- Mold Clamp
  - Provides highest reliability performance by eliminating leadframe-epoxy delamination after solder reflow
- Reflector Step Down
  - Perfect SMT pick-up due to epoxy overfill being eliminated
- Package Bottom Chamfer
  - Perfect lead forming giving high reliability performance (no lead over-formed), and no “tomb-stoning” defect after solder reflow

### Target Markets and Applications

- Interior automotive
  - Instrument panel backlighting
  - Central console backlighting
  - Cabin backlighting
- Exterior automotive
  - Turn signals
  - Side repeater lamps
  - CHMSLs (center high-mounted stop light)
  - Rear combination lamps
  - Puddle lights
- Electronic Signs and Signals
  - Interior full color sign
  - Variable message sign
- Office Automation, Electrical Appliances, Industrial Equipment
  - Front panel backlighting
  - Push button backlighting
  - Display backlighting

# LED Solutions

## PLCC Surface Mount LEDs

### PLCC-2

Part Number	Color	Dominant Wavelength $\lambda_p$ (nm)	Viewing Angle $2\theta_{1/2}$ (°)	$I_v$ @ 20 mA		$V_f$ @ 20 mA Typ. (V)
				Min. (mcd)	Typ. (mcd)	
HSMS-A100-L00J1	GaP Red	626	120	10	15	2.2
HSMH-A100-N00J1	AlGaAs Red	637	120	25	50	1.9
HSMC-A100-Q00J1	AllnGaP Red	626	120	63	100	1.9
HSMC-A100-R00J1	AllnGaP Red	626	120	100	140	1.9
HSMC-A101-S00J1	AllnGaP Red	626	120	160	220	1.9
HSMZ-A100-T00J1	AllnGaP Red	630	120	250	350	2.2
HSMJ-A100-Q00J1	AllnGaP Red Orange	615	120	63	100	1.9
HSMJ-A101-S00J1	AllnGaP Red Orange	615	120	160	200	1.9
HSMV-A100-T00J1	AllnGaP Red Orange	617	120	250	350	2.2
HSMO-A100-L00J1	GaP Orange	602	120	10	15	2.2
HSML-A100-Q00J1	AllnGaP Orange	605	120	63	100	1.9
HSML-A101-S00J1	AllnGaP Orange	605	120	160	220	1.9
HSMY-A100-L00J1	GaP Amber	585	120	10	12	2.2
HSMA-A100-Q00J1	AllnGaP Amber	590	120	63	100	1.9
HSMA-A101-S00J1	AllnGaP Amber	590	120	160	220	1.9
HSMU-A100-S00J1	AllnGaP Amber	592	120	160	320	2.2
HSMG-A100-J02J1	GaP Yellow Green	569	120	4	18	2.2
HSME-A100-M02J1	AllnGaP Yellow Green	570	120	16	70	1.9
HSMG-A100-H01J1	GaP Emerald Green	560	120	2.5	8	2.2
HSME-A100-L01J1	AllnGaP Emerald Green	560	120	10	40	1.9
HSMO-A101-R00J1	InGaN Green	525	120	100	200	3.4
HSMO-A100-S00J1	InGaN Green	525	120	160	350	3.4
HSMK-A101-R00J1	InGaN Cyan	505	120	100	170	3.4
HSMK-A100-S00J1	InGaN Cyan	505	120	160	280	3.4
HSMB-A100-J00J1	GaN Blue	462	120	4	15	3.9
HSMN-A101-N00J1	InGaN Blue	470	120	25	50	3.4
HSMN-A100-P00J1	InGaN Blue	470	120	40	70	3.4

**Notes:**

1. The luminous intensity  $I_v$  is measured at the mechanical axis of the lamp package. The actual peak of the spatial radiation pattern may not be aligned with this axis.
2. The dominant wavelength,  $\lambda_p$ , is derived from the CIE Chromaticity Diagram and represents the color of the device.
3.  $\theta_{1/2}$  is the off-axis angle where the luminous intensity is 1/2 the peak intensity.

### PLCC-2 White

Part Number	Color	Chromaticity Coordinates		Viewing Angle $2\theta_{1/2}$ (°)	$I_v$ @ 20 mA		$V_f$ @ 20 mA Typ. (V)
		x	y		Min. (mcd)	Typ. (mcd)	
HSMW-A101-R50J1	InGaN White	0.31	0.31	120	100	—	3.4
HSMW-A100-T50J1	InGaN White	0.31	0.31	120	250	—	3.4

**Notes:**

1. The luminous intensity  $I_v$  is measured at the mechanical axis of the lamp package. The actual peak of the spatial radiation pattern may not be aligned with this axis.
2. The chromaticity coordinates are derived from the CIE 1931 Chromaticity Diagram and represents the perceived color of the device.
3.  $\theta_{1/2}$  is the off-axis angle where the luminous intensity is 1/2 the peak intensity.

## PLCC Surface Mount LEDs

### Power PLCC-4

Part Number	Color	Dominant Wavelength $\lambda_D^{[1]}$ (nm)	Viewing Angle $2\theta_{1/2}^{[2]}$ (Degrees)	Min. $I_V$ (mcd)	Max. $I_V$ (mcd)	Typ. $V_F$ (V)	Test Current (mA)
HSMC-A400-S30M1	AllInGaP Red	626	120	160	395	2.2	50
HSMC-A401-T40M1	AllInGaP Red	626	120	250	800	2.2	50
HSMC-A401-T80M1	AllInGaP Red	626	120	310	1000	2.2	50
HSMZ-A400-U80M1	AllInGaP Red	630	120	500	1600	2.8	50
HSMJ-A401-T40M1	AllInGaP Red Orange	615	120	250	800	2.2	50
HSMJ-A401-U40M1	AllInGaP Red Orange	615	120	400	1260	2.2	50
HSMV-A400-U80M1	AllInGaP Red Orange	617	120	500	1600	2.8	50
HSML-A401-U40M1	AllInGaP Orange	605	120	400	1260	2.2	50
HSMA-A400-T35M1	AllInGaP Amber	590	120	250	620	2.2	50
HSMA-A401-U45M1	AllInGaP Amber	590	120	400	1260	2.2	50
HSMU-A400-U85M1	AllInGaP Amber	592	120	500	1600	2.8	50
HSME-A401-P4PM1	AllInGaP Emerald Green	567	120	40	130	2.2	50
HSMM-A401-S4YM2	InGaN Green	525	120	160	500	3.8	30
HSMM-A401-S7YM2	InGaN Green	525	120	200	500	3.8	30
HSMM-A400-T8YM2	InGaN Green	525	120	310	1000	3.8	30
HSMK-A401-R40M2	InGaN Cyan	505	120	100	315	3.8	30
HSMK-A400-T80M2	InGaN Cyan	505	120	310	1000	3.8	30
HSMN-A401-P4QM2	InGaN Blue	470	120	40	130	3.8	30
HSMN-A401-P7QM2	InGaN Blue	470	120	50	130	3.8	30
HSMN-A400-Q8QM2	InGaN Blue	470	120	80	250	3.8	30

**Notes:**

1. The dominant wavelength,  $\lambda_D$ , is derived from the CIE Chromaticity Diagram and represents the color of the device.
2.  $\theta_{1/2}$  is the off-axis angle where the luminous intensity is 1/2 the peak intensity.
3. The luminous intensity,  $I_V$ , is measured at the mechanical axis of the lamp package. The actual peak of the spatial radiation pattern may not be aligned with this axis.

### Power PLCC-4 White

Part Number	Color	Chromaticity Coordinates		Viewing Angle $2\theta_{1/2}$ (°)	$I_V$ @ 30 mA			VF @ 30 mA Typ. (V)
		x	y		Min. (mcd)	Typ. (mcd)	Max. (mcd)	
HSMW-A400-T00M2	InGaN White	0.31	0.31	120	285.00	560.00	-	3.8
HSMW-A400-U00M2	InGaN White	0.31	0.31	120	450.00	700.00	-	3.8
ASMT-SWBM-NU803 <sup>[5]</sup>	InGaN White	0.318	0.318	120	560.00	1100.00	1400.00	3.5

**Notes:**

1. The luminous intensity  $I_V$ , is measured at the mechanical axis of the lamp package. The actual peak of the spatial radiation pattern may not be aligned with this axis.
2.  $I_V$  Tolerance =  $\pm 12\%$
3. The chromaticity coordinates are derived from the CIE 1931 Chromaticity Diagram and represent the perceived color of the device.
4.  $\theta_{1/2}$  is the off-axis angle where the luminous intensity is 1/2 the peak intensity.
5. Long Life White Device

## PLCC Surface Mount LEDs

### Power PLCC-4 with Lens

Part Number	Color	Dominant Wavelength $\lambda_D^{(1)}$ (nm)	Viewing Angle $2\theta_{1/2}$ (°)	Min. $I_v$ (mcd)	Max. $I_v$ (mcd)	Typ. $V_f$ (V)	Test Current (mA)
HSMC-A431-Y80M1	AllInGaP Red	626	30	3550	9000	2.2	50
HSMC-A431-X90M1	AllInGaP Red	626	30	2240	7150	2.2	50
HSMC-A461-V00M1	AllInGaP Red	626	50	715	–	2.2	50
HSMJ-A430-W50M1	AllInGaP Red Orange	615	30	1125	3550	2.2	50
HSMJ-A431-X90M1	AllInGaP Red Orange	615	30	2240	7150	2.2	50
HSMV-A430-Y90M1	AllInGaP Red Orange	617	30	3500	11250	2.8	50
HSMJ-A461-W40M1	AllInGaP Red Orange	615	50	1125	2850	2.2	50
HSML-A431-X90M1	AllInGaP Orange	605	30	2240	7150	2.2	50
HSML-A461-W40M1	AllInGaP Orange	605	50	1125	2850	2.2	50
HSMA-A431-Y00M1	AllInGaP Amber	590	30	2850	–	2.2	50
HSMA-A431-Z50M1	AllInGaP Amber	590	30	4500	14000	2.2	50
HSMA-A461-X83M1	AllInGaP Amber	590	50	2240	5600	2.2	50
HSMH-A430-W90M2	InGaN Green	525	30	1400	4500	3.9	30
HSMN-A430-U50M2	InGaN Blue	470	30	450	1400	3.9	30
HSMN-A431-T50M2	InGaN Blue	470	30	285	900	3.9	30

#### Notes:

1. The luminous intensity,  $I_v$ , is measured at the mechanical axis of the lamp package. The actual peak of the spatial radiation pattern may not be aligned with this axis.
2.  $I_v$  tolerance  $\pm 12\%$
3. The dominant wavelength,  $\lambda_D$ , is derived from the CIE Chromaticity Diagram and represents the color of the device.
4.  $\theta_{1/2}$  is the off-axis angle where the luminous intensity is  $1/2$  the peak intensity.

# LED Solutions

## PLCC Surface Mount LEDs

### Bicolor PLCC-4

Part Number	Color	Min. $I_v$ @ 20mA		Typ. $I_v$ (mcd) @ 20mA
		Bin ID	mcd	
HSMF-A201-A00J1	GaP Red	K2	8	16
	GaP Yellow Green	L1	10	20
HSMF-A202-A00J1	GaP Red	K2	8	16
	GaP Yellow	K1	6.3	12
HSMF-A203-A00J1	GaP Red	K2	8	16
	GaP Emerald Green	J1	4	8
HSMF-A204-A00J1	GaP Orange	K2	8	16
	GaP Yellow Green	L1	10	20
HSMF-A205-A00J1	GaP Orange	K2	8	16
	GaP Emerald Green	J1	4	8
HSMF-A206-A00J1	GaP Yellow	K2	8	16
	GaP Yellow Green	L1	10	20
HSMF-A211-A00J1	AlGaAs Red	L2	12.5	25
	GaP Yellow Green	L1	10	20
HSMF-A212-A00J1	AlGaAs Red	L2	12.5	25
	GaP Yellow	K1	6.3	12
HSMF-A222-A00J1	AllInGaP Red	P1	40	80
	AllInGaP Amber	P1	40	80
HSMF-A226-A00J1	AllInGaP Amber	P2	50	100
	AllInGaP Yellow Green	M2	20	60
HSMF-A227-A00J1	AllInGaP Red	P1	40	80
	GaN Blue	J2	5	10
HSMF-A228-A00J1	AllInGaP Amber	P1	40	80
	GaN Blue	J2	5	10

### Tricolor PLCC-4

Part Number	Color	Min. $I_v$ @ 20mA		Typ. $I_v$ (mcd) @ 20mA
		Bin ID	mcd	
ASMT-QTB0-0AA02	AllInGaP Red	U1	450	620
	InGaN Green	V2	900	1200
	InGaN Blue	S2	224	280
ASMT-QTC0-0AA02*	AllInGaP Red	S1	180	315
	InGaN Green	T1	285	470
	InGaN Blue	R1	112.5	140
HSMF-A301-A00J1	GaP Red	K2	8	13
	GaP Yellow Green	L2	12.5	20
	GaN Blue	K2	8	10
HSMF-A331-A00J1	AllInGaP Red	P1	40	80
	InGaN Green	R1	100	160
	GaN Blue	K2	8	10
HSMF-A332-A00J1	AllInGaP Red Orange	P1	40	80
	InGaN Green	R1	100	160
	GaN Blue	K2	8	10
HSMF-A341-A00J1	AllInGaP Red	P1	40	80
	InGaN Green	R1	100	160
	InGaN Blue	N1	25	40
HSMF-A342-A00J1	AllInGaP Red Orange	P1	40	80
	InGaN Green	R1	100	160
	InGaN Blue	N1	25	40

Notes:  
\*Blackbody

### Super 0.5W Power PLCC-4

Part Number	Color	Dominant Wavelength $\lambda_d^{(1)}$ (nm)	Viewing Angle $2\theta_{1/2}^{(2)}$ (°)	Flux Bin	Min. Flux (lm)	Max. Flux (lm)	Typ. $V_f$ (V)	Test Current (mA)
ASMT-QAB2-FDE0E	AllInGaP Amber	594.5	120	D	9.00	11.50	2.70	150
				E	11.50	15.00		
ASMT-QHB2-FEFOE	AllInGaP Red Orange	617.0	120	E	11.50	15.00	2.70	150
				F	15.00	19.50		
ASMT-QRB2-FCDOE	AllInGaP Red	624.0	120	C	7.00	9.00	3.10	150
				D	9.00	11.50		
ASMT-QBBE-NOBOE **	InGaN Blue	464.5	120	O	3.40	4.30	3.6	150
				A	4.30	5.50		
				B	5.50	7.00		
ASMT-QGBE-NEGOE **	InGaN Green	522.0	120	E	11.50	15.00	3.6	150
				F	15.00	19.50		
				G	19.50	25.50		

**Notes:**

- The dominant wavelength,  $\lambda_d$ , is derived from the CIE Chromaticity diagram and represents the color of the device.
- $\theta_{1/2}$  is the off-axis angle where the luminous intensity is 1/2 the peak intensity.
- Radiant intensity,  $I_e$  in watts / steradian, may be calculated from the equation  $I_e = I_v / \eta_v$ , where  $I_v$  is the luminous intensity in candelas and  $\eta_v$  is the luminous efficacy in lumens/watt.
- $\Phi_v$  is the total luminous flux output as measured with an integrating sphere at mono pulse conditions.
- Tolerance =  $\pm 12\%$ .

\*\*Not for Japan

# LED Solutions

## PLCC Surface Mount LEDs

### Super 0.5W White Power PLCC-4

Part Number	Color	Chromaticity Coordinates		Viewing Angle $2\theta_{1/2}$ (°)	Flux Bin	Min. Flux (lm)	Max. Flux (lm)	Typ. $V_F$ (V)	Test Current (mA)
		x	y						
ASMT-QWBE-NFHOE **	InGaN Cool White	0.33	0.33	120	F	15.00	19.50	3.6	150
					G	19.50	25.50		
					H	25.50	33.00		
ASMT-QYBE-NEGOE **	InGaN Warm White	0.44	0.41	120	E	11.50	15.00	3.6	150
					F	15.00	19.50		
					G	19.50	25.50		
ASMT-QWBB-NGHOE	InGaN Cool White	0.32	0.31	120	G	19.50	25.50	3.5	150
					H	25.50	33.00		
ASMT-QYBB-NFGOE	InGaN Warm White	0.41	0.39	120	F	15.00	19.50	3.5	150
					G	19.50	25.50		

#### Notes:

1. The dominant wavelength,  $\lambda_D$ , is derived from the CIE Chromaticity diagram and represents the color of the device.
2.  $\theta_{1/2}$  is the off-axis angle where the luminous intensity is 1/2 the peak intensity.
3. Radiant intensity,  $I_e$  in watts / steradian, may be calculated from the equation  $I_e = I_v / \eta_V$ , where  $I_v$  is the luminous intensity in candelas and  $\eta_V$  is the luminous efficacy in lumens/watt.
4.  $\Phi_V$  is the total luminous flux output as measured with an integrating sphere at mono pulse conditions.
5. Tolerance =  $\pm 12\%$ .

\*\*Not for Japan

### PLCC-6

Part Number	Color	Min. $I_v$ @ 20mA		Typ. $I_v$ (mcd) @ 20mA
		Bin ID	mcd	
ASMT-YTBO-OAA02	AllInGaP Red	U1	450	640
	InGaN Green	V2	900	1200
	InGaN Blue	S2	224	240

#### Notes:

1. The luminous intensity  $I_v$ , is measured at the mechanical axis of the lamp package. The actual peak of the spatial radiation pattern may not be aligned with this axis.
2.  $I_v$  Tolerance =  $\pm 12\%$
3. The chromaticity coordinates are derived from the CIE 1931 Chromaticity Diagram and represent the perceived color of the device.
4.  $\theta_{1/2}$  is the off-axis angle where the luminous intensity is 1/2 the peak intensity.

# LED Solutions

## PLCC Surface Mount LEDs

### Intensity Bin Select ( $X_5, X_6$ )

Individual reel will contain parts from 1 half bin only. Single color (see data sheet for bicolor and tricolor).

$X_5$	Minimum Iv Bin
$X_6$	
0	Full Distribution
2	2 half bins starting from $X_5,1$
3	3 half bins starting from $X_5,1$
4	4 half bins starting from $X_5,1$
5	5 half bins starting from $X_5,1$
6	2 half bins starting from $X_5,2$
7	3 half bins starting from $X_5,2$
8	4 half bins starting from $X_5,2$
9	5 half bins starting from $X_5,2$

### Color Bin Select ( $X_7$ )

Individual reel will contain parts from 1 full bin only. Single color (see data sheet for bicolor and tricolor).

$X_7$	
0	Full Distribution
Z	A and B only
Y	B and C only
W	C and D only
V	D and E only
U	E and F only
T	F and G only
S	G and H only
Q	A, B and C only
P	B, C and D only
N	C, D and E only
M	D, E and F only
L	E, F and G only
K	F, G and H only
1	A, B, C and D only
2	E, F, G and H only
3	B, C, D and E only
4	C, D, E and F only
5	A, B, C, D and E only
6	B, C, D, E and F only

### Color Bin Limits (HSMW-Axxx)

Bin ID	Limits (Chromaticity Coordinates)
A	X 0.352 0.365 0.365 0.352
	Y 0.377 0.395 0.360 0.341
B	X 0.340 0.352 0.352 0.340
	Y 0.360 0.377 0.341 0.325
C	X 0.327 0.340 0.340 0.327
	Y 0.342 0.360 0.325 0.306
D	X 0.315 0.327 0.327 0.315
	Y 0.325 0.342 0.306 0.290
E	X 0.302 0.315 0.315 0.302
	Y 0.307 0.325 0.290 0.271
F	X 0.290 0.302 0.302 0.290
	Y 0.290 0.307 0.271 0.255

Tolerance of each bin limit =  $\pm 0.02$ .

### Intensity Bin Limits

Bin ID	Intensity (mcd)	
	Min.	Max.
J1	4.50	5.60
J2	5.60	7.20
K1	7.20	9.00
K2	9.00	11.20
L1	11.20	14.00
L2	14.00	18.00
M1	18.00	22.40
M2	22.40	28.50
N1	28.50	35.50
N2	35.50	45.00
P1	45.00	56.00
P2	56.00	71.50
Q1	71.50	90.00
Q2	90.00	112.50
R1	112.50	140.00
R2	140.00	180.00
S1	180.00	224.00
S2	224.00	285.00
T1	285.00	355.00
T2	355.00	450.00
U1	450.00	560.00
U2	560.00	715.00
V1	715.00	900.00
V2	900.00	1125.00
W1	1125.00	1400.00
W2	1400.00	1800.00
X1	1800.00	2240.00
X2	2240.00	2850.00
Y1	2850.00	3550.00
Y2	3550.00	4500.00
Z1	4500.00	5600.00
Z2	5600.00	7150.00
11	7150.00	9000.00
12	9000.00	11250.00
21	11250.00	14000.00
22	14000.00	18000.00

Tolerance of each bin limit =  $\pm 12\%$

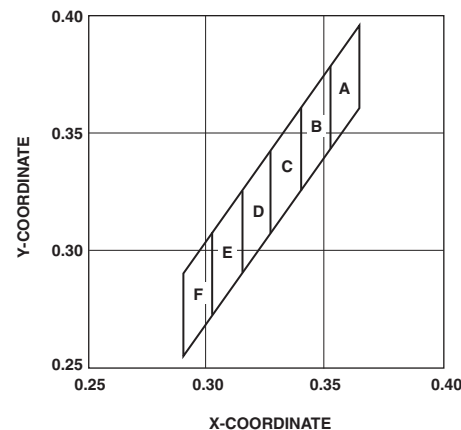

### Color Bin Limits

Color/Bin	Wavelength (nm)	
	Min.	Max.
<b>Blue</b>		
A	460.0	465.0
B	465.0	470.0
C	470.0	475.0
D	475.0	480.0
<b>Cyan</b>		
A	490.0	495.0
B	495.0	500.0
C	500.0	505.0
D	505.0	510.0
<b>Green</b>		
A	515.0	520.0
B	520.0	525.0
C	525.0	530.0
D	530.0	535.0
<b>Yellow Green/Emerald Green</b>		
A	552.5	555.5
B	555.5	558.5
C	558.5	561.5
D	561.5	564.5
E	564.5	567.5
F	567.5	570.5
G	570.5	573.5
H	573.5	576.5
<b>Amber</b>		
A	582.0	584.5
B	584.5	587.0
C	587.0	589.5
D	589.5	592.0
E	592.0	594.5
F	594.5	597.0
<b>Orange</b>		
A	597.0	600.0
B	600.0	603.0
C	603.0	606.0
D	606.0	609.0
E	609.0	612.0
<b>Red Orange</b>		
A	611.0	616.0
B	616.0	620.0
<b>Red</b>		
Full Distribution	620	635

Tolerance of each bin limit =  $\pm 1\text{nm}$

### Tricolor/Power PLCC-4

1	Cathode (Color 1)
2	Common Anode
3	Cathode (Color 3)
4	Cathode (Color 2)

### Bicolor PLCC-4

1	Cathode (Color 1)
2	Anode (Color 1)
3	Cathode (Color 2)
4	Anode (Color 2)

# LED Solutions

## PLCC Surface Mount LEDs

### Packaging Option (X<sub>8</sub>X<sub>9</sub>)

Option	Test Current	Package Type	Reel Size
M1	50 mA	Top Mount	7/13 Inch
M2	30 mA	Top Mount	7/13 Inch
J1	20 mA	Top Mount	7 Inch
J4	20 mA	Top Mount	13 Inch
H1	20 mA	Reverse Mount	7 Inch
H4	20 mA	Reverse Mount	13 Inch

### Intensity Bin Select (X<sub>2</sub>X<sub>3</sub>) for ASMT-SWBM-Nxxxx

Individual reel will contain parts from one half bin only.

X <sub>5</sub>	Minimum I <sub>v</sub> Bin
X <sub>3</sub>	
0	Full Distribution
2	2 half bins starting from X <sub>1</sub>
3	3 half bins starting from X <sub>1</sub>
4	4 half bins starting from X <sub>1</sub>
5	5 half bins starting from X <sub>1</sub>
6	2 half bins starting from X <sub>2</sub>
7	3 half bins starting from X <sub>2</sub>
8	4 half bins starting from X <sub>2</sub>
9	5 half bins starting from X <sub>2</sub>

### Intensity Bin Limits

Bin ID	Min. (mcd)	Max. (mcd)
N1	28.50	35.50
N2	35.50	45.00
P1	45.00	56.00
P2	56.00	71.50
Q1	71.50	90.00
Q2	90.00	112.50
R1	112.50	140.00
R2	140.00	180.00
S1	180.00	224.00
S2	224.00	285.00
T1	285.00	355.00
T2	355.00	450.00
U1	450.00	560.00
U2	560.00	715.00
V1	715.00	900.00
V2	900.00	1125.00
W1	1125.00	1400.00
W2	1400.00	1800.00

Tolerance of each bin limit = ± 12%

### Color Bin Select (X<sub>4</sub>)

Individual reel will contain parts from one full bin only.

X <sub>4</sub>	Minimum I <sub>v</sub> Bin
0	Full Distribution
A	1 and 2 only
B	2 and 3 only
C	3 and 4 only
D	4 and 5 only
E	5 and 6 only
F	6 and 7 only
G	1, 2 and 3 only
H	2, 3 and 4 only
J	3, 4 and 5 only
K	4, 5 and 6 only
L	5, 6 and 7 only
M	1, 2, 3 and 4 only
N	2, 3, 4 and 5 only
P	3, 4, 5 and 6 only
Q	4, 5, 6 and 7 only
R	1, 2, 3, 4 and 5 only
S	2, 3, 4, 5 and 6 only
T	3, 4, 5, 6, and 7 only
U	1, 2, 3, 4, 5 and 6 only
V	2, 3, 4, 5, 6 and 7 only
Z	Special Color Bin

### Color Bin Limits

Bin ID	Limits (Chromaticity Coordinates)				
1	x	0.296	0.291	0.310	0.313
	y	0.259	0.268	0.297	0.284
2	x	0.291	0.285	0.307	0.310
	y	0.268	0.279	0.312	0.297
3	x	0.313	0.310	0.330	0.330
	y	0.284	0.297	0.330	0.310
4	x	0.310	0.307	0.330	0.330
	y	0.297	0.312	0.347	0.330
5	x	0.330	0.330	0.338	0.352
	y	0.310	0.330	0.342	0.344
6	x	0.330	0.330	0.347	0.345
	y	0.330	0.347	0.371	0.352
7	x	0.352	0.338	0.364	0.360
	y	0.344	0.342	0.380	0.357
8	x	0.345	0.347	0.367	0.364
	y	0.352	0.371	0.401	0.380

Tolerance of each bin limit = ± 0.02

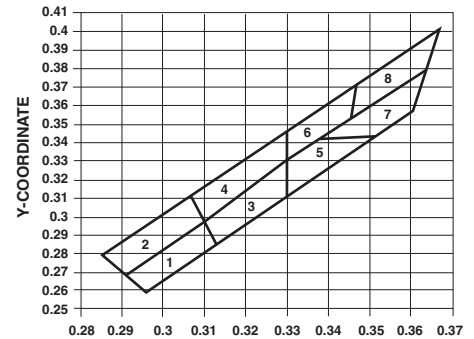

### Packaging Option (X<sub>3</sub>)

Option	Test Current	Package Type	Reel Size
3	30 mA	Top Mount	7 inch

### V<sub>F</sub> Bin Limits

Bin ID	Min.	Max.
S3	3.20	3.80
S4	3.80	4.35

Tolerance of each bin limit = ± 0.1V

# LED Solutions

## Tricolor PLCC-4 (ASMT-QTB0,ASMT-QTCO) and Tricolor PLCC-6 (ASMT-YTB0)

### Intensity Bin Select ( $X_2, X_3$ ) for ASMT-QTB0/YTB0

Individual reel will contain parts from one half bin only.

$X_2$	Min Iv Bin (Minimum Intensity Bin)		
	Red	Green	Blue
0	0	0	0
A	U1	V2	S2

$X_3$	Number of Half Bin from $X_2$		
	Red	Green	Blue
0	0	0	0
A	4	4	4

Note: 0 represents no maximum bin limit

### For ASMT-QTCO

$X_2$	Min Iv Bin (Minimum Intensity Bin)		
	Red	Green	Blue
0	0	0	0
A	S1	T1	R1

$X_3$	Number of Half Bin from $X_2$		
	Red	Green	Blue
0	0	0	0
A	4	4	4

### Color Bin Select ( $X_4$ )

Individual reel will contain parts from one full bin only.

$X_4$	Color Bin Combinations		
	Red	Green	Blue
0	Full Distribution	C & D	B & C

### Intensity Bin Limits

Bin ID	Min (mcd)	Max (mcd)
R1	112.5	140
R2	140	180
S1	180	224
S2	224	285
T1	285	355
T2	355	450
U1	450	560
U2	560	715
V1	715	900
V2	900	1125
W1	1125	1400
W2	1400	1800
X1	1800	2240

Tolerance of each bin limit =  $\pm 12\%$

### Color Bin Limits

Red	Min (nm)	Max (nm)
Full Distribution	618	628

Green	Min (nm)	Max (nm)
C	525	530
D	530	535

Blue	Min (nm)	Max (nm)
B	465	470
C	470	475

Tolerance of each bin limit =  $\pm 1$  nm





### Packaging Option ( $X_5$ )

Please refer to respective datasheet for related information.

# LED Solutions

## Super 0.5W Power PLCC-4

### Device Color (X<sub>1</sub>)

A		Amber
B		Blue
G		Green
H		Red Orange
R		Red

### Flux Bin Select (X<sub>2</sub>X<sub>3</sub>)

Individual reel will contain parts from one bin only

X2	Min Flux Bin
X3	Max Flux Bin

### Flux Bin Limits

Bin ID	Min. (lm)	Max. (lm)
0	3.40	4.30
A	4.30	5.50
B	5.50	7.00
C	7.00	9.00
D	9.00	11.50
E	11.50	15.00
F	15.00	19.50
G	19.50	25.50
H	25.50	33.00
J	33.00	43.00
K	43.00	56.00
L	56.00	73.00

Tolerance of each bin limit = ± 12%

### Color Bin Select (X<sub>4</sub>)

Individual reel will contain parts from one full bin only.

X <sub>4</sub>	
0	Full Distribution
A	1 and 2 only
B	2 and 3 only
C	3 and 4 only
D	4 and 5 only
E	5 and 6 only
G	1, 2 and 3 only
H	2, 3 and 4 only
J	3, 4 and 5 only
K	4, 5 and 6 only
M	1, 2, 3 and 4 only
N	2, 3, 4 and 5 only
P	3, 4, 5 and 6 only
R	1, 2, 3, 4 and 5 only
S	2, 3, 4, 5 and 6 only
Z	Special Color Bin

### Color Bin Limits

Color/Bin	Wavelength (nm)	
	Min.	Max.
<b>Blue</b>		
1	460.0	465.0
2	465.0	470.0
3	470.0	475.0
4	475.0	480.0
<b>Green</b>		
1	515.0	520.0
2	520.0	525.0
3	525.0	530.0
4	530.0	535.0
<b>Amber</b>		
2	583.0	586.0
3	586.0	589.0
4	589.0	592.0
5	592.0	595.0
6	595.0	598.0
<b>Red Orange</b>		
1	611.0	616.0
2	616.0	620.0
3	620.0	625.0
<b>Red</b>		
Full Distribution	620.0	635.0

Tolerance of each bin limit = ± 1nm

# LED Solutions

## Super 0.5W White Power PLCC-4 Surface Mount LED

### $V_f$ Binning for AlInGaP Devices (ASMT-QAxx/QHxx/QRxx)

Bin ID	Min.	Max.
2D	2.35	2.50
2E	2.50	2.65
2F	2.65	2.80
2G	2.80	2.95
2H	2.95	3.10
2J	3.10	3.25
2K	3.25	3.40
2L	3.40	3.55
2M	3.55	3.70
2N	3.70	3.85

Tolerance of each bin limit =  $\pm 0.1V$

### $V_f$ Bin Limits for InGaN Devices (ASMT-QBxx/QGxx)

Bin ID	Min.	Max.
S5	3.20	3.50
S6	3.50	3.80
S7	3.80	4.10

Tolerance of each bin limit =  $\pm 0.1V$

### Packaging Option ( $X_1$ )

Option	Test Current	Package Type	Reel Size
E	150 mA	Top Mount	7 inch

### Device Color ( $X_1$ )

W	Cool White
Y	Warm White

### Flux Bin Select ( $X_2, X_3$ )

Individual reel will contain parts from one bin only

$X_2$	Min Flux Bin
$X_3$	Min Flux Bin

### Flux Bin Limits

Bin ID	Min. (lm)	Max. (lm)
O	3.40	4.30
A	4.30	5.50
B	5.50	7.00
C	7.00	9.00
D	9.00	11.50
E	11.50	15.00
F	15.00	19.50
G	19.50	25.50
H	25.50	33.00
J	33.00	43.00
K	43.00	56.00
L	56.00	73.00

Tolerance of each bin limit =  $\pm 12\%$

### Color Bin Select ( $X_4$ ) for ASMT-QWBE/QWBB-Nxxxx

Individual reel will contain parts from one sub bin only.

$X_4$	
O	Full Distribution
A	5K and 5L only
B	6K and 6L only
C	7K and 7L only
D	8K and 8L only
E	5K and 6K only
F	5L and 6L only
G	6K and 7K only
H	6L and 7L only
J	7K and 8K only
K	7L and 8L only
L	5K, 5L, 6K and 6L only
M	6K, 6L, 7K and 7L only
N	7K, 7L, 8K and 8L only
Z	Special binning

### Color Bin Limits for ASMT-QWBE/QWBB

Bin ID	Sub Bin ID	Limits (Chromaticity Coordinates)					
5K	5Ka	x	0.296	0.304	0.302	0.294	
		y	0.259	0.270	0.276	0.264	
	5Kb	x	0.294	0.302	0.300	0.291	
		y	0.264	0.276	0.281	0.268	
	5Kc	x	0.304	0.313	0.312	0.302	
		y	0.270	0.284	0.291	0.276	
	5Kd	x	0.302	0.312	0.310	0.300	
		y	0.276	0.291	0.297	0.281	
	5L	5La	x	0.291	0.300	0.298	0.288
			y	0.268	0.281	0.288	0.274
		5Lb	x	0.288	0.298	0.295	0.285
			y	0.274	0.288	0.294	0.279
5Lc		x	0.300	0.310	0.309	0.298	
		y	0.281	0.297	0.305	0.288	
5Ld		x	0.298	0.309	0.307	0.295	
		y	0.288	0.305	0.312	0.294	
6K		6Ka	x	0.313	0.322	0.321	0.312
			y	0.284	0.297	0.305	0.291
		6Kb	x	0.312	0.321	0.320	0.310
			y	0.291	0.305	0.314	0.297
	6Kc	x	0.322	0.330	0.330	0.321	
		y	0.297	0.310	0.320	0.305	
	6Kd	x	0.321	0.330	0.330	0.320	
		y	0.305	0.320	0.330	0.314	

Tolerance of each bin limit =  $\pm 0.02$ .

### Color Bin Limits for ASMT-QWBE/QWBB cont.

Bin ID	Sub Bin ID	Limits (Chromaticity Coordinates)					
6L	6La	x	0.310	0.320	0.319	0.309	
		y	0.297	0.314	0.322	0.305	
	6Lb	x	0.309	0.319	0.318	0.307	
		y	0.305	0.322	0.329	0.312	
	6Lc	x	0.320	0.330	0.330	0.319	
		y	0.314	0.330	0.339	0.322	
	6Ld	x	0.319	0.330	0.330	0.318	
		y	0.322	0.339	0.347	0.329	
	7K	7Ka	x	0.330	0.336	0.337	0.330
			y	0.310	0.320	0.330	0.320
7Kb		x	0.330	0.337	0.337	0.330	
		y	0.320	0.330	0.341	0.330	
7Kc		x	0.336	0.343	0.344	0.337	
		y	0.320	0.331	0.341	0.330	
7Kd		x	0.337	0.344	0.345	0.337	
		y	0.330	0.341	0.352	0.341	
7L		7La	x	0.330	0.337	0.337	0.330
			y	0.330	0.341	0.349	0.339
	7Lb	x	0.330	0.337	0.338	0.330	
		y	0.339	0.349	0.358	0.347	
	7Lc	x	0.337	0.345	0.346	0.337	
		y	0.341	0.352	0.362	0.349	
	7Ld	x	0.337	0.346	0.347	0.338	
		y	0.349	0.362	0.371	0.358	
8K	8Ka	x	0.343	0.351	0.352	0.344	
		y	0.331	0.343	0.354	0.341	
	8Kb	x	0.344	0.352	0.354	0.345	
		y	0.341	0.354	0.364	0.352	
	8Kc	x	0.351	0.360	0.362	0.352	
		y	0.343	0.357	0.369	0.354	
	8Kd	x	0.352	0.362	0.364	0.354	
		y	0.354	0.369	0.380	0.364	
8L	8La	x	0.345	0.354	0.355	0.346	
		y	0.352	0.364	0.375	0.362	
	8Lb	x	0.346	0.355	0.356	0.347	
		y	0.362	0.375	0.385	0.371	
	8Lc	x	0.354	0.364	0.366	0.355	
		y	0.364	0.380	0.391	0.375	
	8Ld	x	0.355	0.366	0.367	0.356	
		y	0.375	0.391	0.401	0.385	

Tolerance of each bin limit =  $\pm 0.02$ .

# LED Solutions

## Super 0.5W White Power PLCC-4 Surface Mount LED

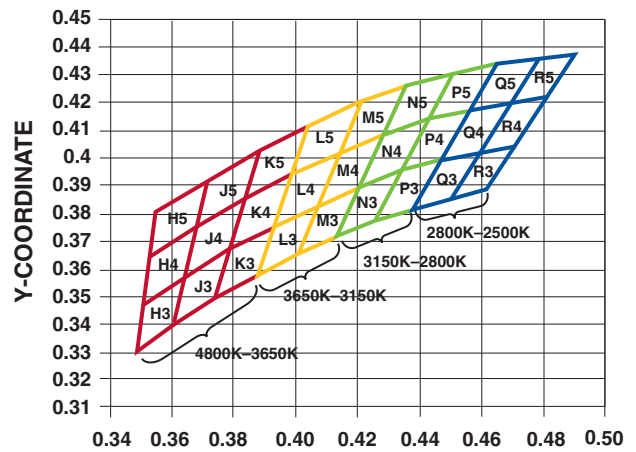
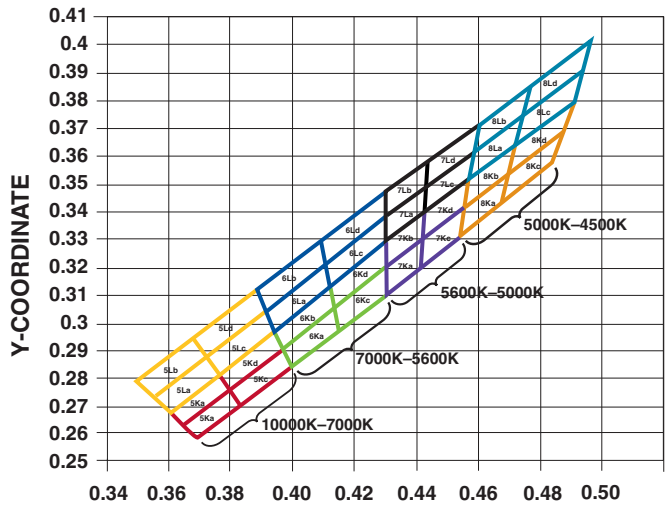

### Color Bin Select ( $X_4$ ) for ASMT-QYBE-Nxxxx

Individual reel will contain parts from one sub bin only.

$X_4$	Description
0	Full Distribution
A	H, J and K only
B	H, J, K, L and M only
C	L and M only
D	L, M, N and P only
E	N and P only
F	N, P, Q and R only
G	Q and R only
Z	Special Color Bin

### Color Bin Limits for QYBE/QYBB-Nxxxx cont.

Bin ID	Sub Bin ID	Limits (Chromaticity Coordinates)				
L	L3	x	0.387	0.400	0.407	0.393
		y	0.358	0.366	0.384	0.376
	L4	x	0.393	0.407	0.414	0.399
		y	0.376	0.384	0.402	0.395
	L5	x	0.399	0.414	0.421	0.405
		y	0.395	0.402	0.420	0.412
M	M3	x	0.400	0.413	0.421	0.407
		y	0.366	0.372	0.390	0.384
	M4	x	0.407	0.421	0.429	0.414
		y	0.384	0.390	0.409	0.402
	M5	x	0.414	0.429	0.436	0.421
		y	0.402	0.409	0.426	0.420
N	N3	x	0.413	0.425	0.434	0.421
		y	0.372	0.378	0.396	0.390
	N4	x	0.421	0.434	0.443	0.429
		y	0.390	0.396	0.414	0.409
	N5	x	0.429	0.443	0.451	0.436
		y	0.409	0.414	0.430	0.426
P	P3	x	0.425	0.438	0.447	0.434
		y	0.378	0.382	0.400	0.396
	P4	x	0.434	0.447	0.456	0.443
		y	0.396	0.400	0.417	0.414
	P5	x	0.443	0.456	0.465	0.451
		y	0.414	0.417	0.434	0.430
Q	Q3	x	0.438	0.450	0.460	0.447
		y	0.382	0.386	0.403	0.400
	Q4	x	0.447	0.460	0.470	0.456
		y	0.400	0.403	0.420	0.417
	Q5	x	0.456	0.470	0.479	0.465
		y	0.417	0.420	0.436	0.434

### Color Bin Limits for QYBE/QYBB-Nxxxx cont.

Bin ID	Sub Bin ID	Limits (Chromaticity Coordinates)				
R	R3	x	0.450	0.462	0.472	0.460
		y	0.386	0.389	0.405	0.403
	R4	x	0.460	0.472	0.482	0.470
		y	0.403	0.405	0.422	0.420
	R5	x	0.470	0.482	0.491	0.479
		y	0.420	0.422	0.437	0.436

Tolerance of each bin limit =  $\pm 0.02$

### $V_f$ Bin Limits for ASMT-QWxx/QYxx

Bin ID	Min.	Max.
S5	3.20	3.50
S6	3.50	3.80
S7	3.80	4.10

Tolerance of each bin limit =  $\pm 0.1V$

### Color Bin Limits for QYBE/QYBB-Nxxxx

Bin ID	Sub Bin ID	Limits (Chromaticity Coordinates)				
H	H3	x	0.348	0.360	0.364	0.350
		y	0.332	0.341	0.358	0.348
	H4	x	0.350	0.364	0.367	0.352
		y	0.348	0.358	0.376	0.365
	H5	x	0.352	0.367	0.371	0.354
		y	0.365	0.376	0.392	0.381
J	J3	x	0.360	0.373	0.378	0.364
		y	0.341	0.350	0.368	0.358
	J4	x	0.364	0.378	0.383	0.367
		y	0.358	0.368	0.386	0.376
	J5	x	0.367	0.383	0.388	0.371
		y	0.376	0.386	0.403	0.392
K	K3	x	0.373	0.387	0.393	0.378
		y	0.350	0.358	0.376	0.368
	K4	x	0.378	0.393	0.399	0.383
		y	0.368	0.376	0.395	0.386
	K5	x	0.383	0.399	0.405	0.388
		y	0.386	0.395	0.412	0.403

### Packaging Option ( $X_3$ )

Option	Test Current	Package Type	Reel Size
E	150 mA	Top Mount	7 inch

Pin	Lead Configuration		
	ASMT-QxB2-Fxxxx	ASMT-QxBE-Nxxxx	ASMT-QxBB-Nxxxx
1	Anode	Cathode	Cathode
2	Cathode	Anode	Anode
3	Cathode	Anode	Anode
4	Anode	Cathode	Cathode
5	Anode	Cathode	Cathode
6	Anode	Cathode	Cathode

## Package Dimensions

### Single Color Top Mount

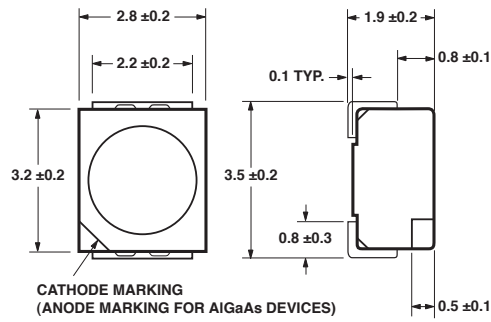

### Single Color Reverse Mount

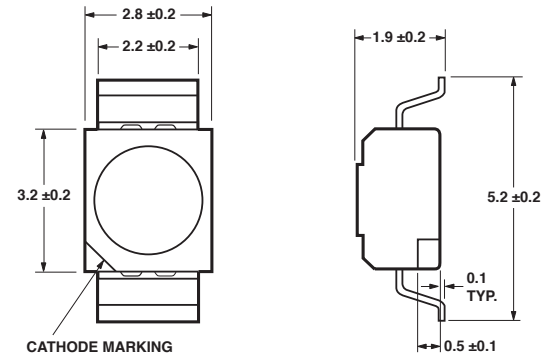

### Power PLCC-4 with Lens

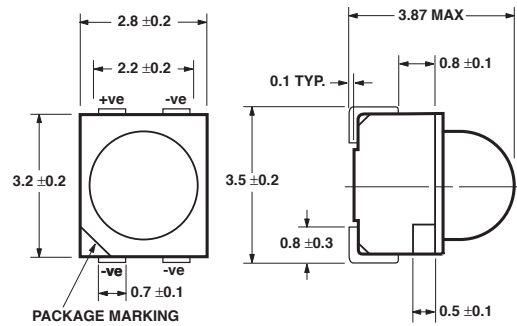

### BiColor/TriColor PLCC4/Power PLCC-4

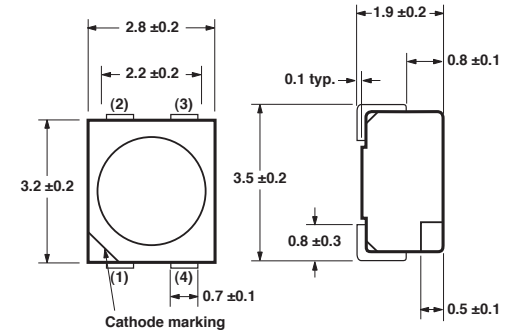

### Super 0.5W Power PLCC-4

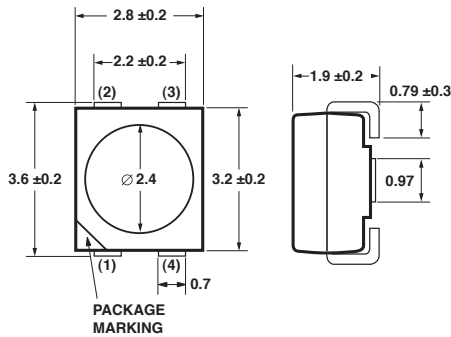

### Blackbody Tricolor PLCC-4

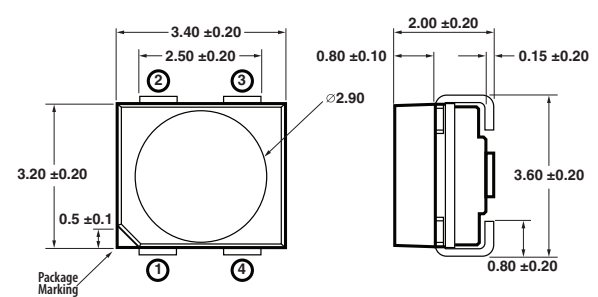

#### NOTE:

1. ALL DIMENSIONS IN MILLIMETERS.
2. TERMINAL FINISH: AG PLATING.
3. ENCAPSULATION MATERIAL: SILICONE RESIN

#### NOTES:

1. ALL DIMENSIONS ARE IN MILLIMETERS
2. TOLERANCE = ± 0.2 MM UNLESS OTHERWISE SPECIFIED
3. TERMINAL FINISH: AG PLATING

### PLCC-6

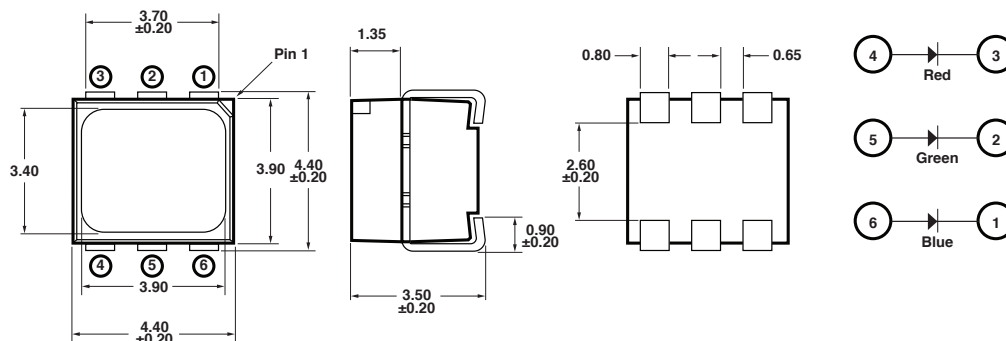



## Envisium™ Power PLCC-4 Surface Mount LEDs

### Description

Envisium Power PLCC-4 (plastic leaded chip carrier) surface-mount (SMT) LEDs represent the premier class of mid-power LEDs from Avago Technologies and Philips Lumileds Lighting, utilizing the very best solid-state lighting technologies from these two industry leaders. Envisium Power PLCC-4 SMT LEDs offer unparalleled performance, reliability and design flexibility. These LEDs produce higher light output with better flux performance compared to conventional PLCC-4 SMT LEDs.

Envisium Power PLCC-4 SMT LEDs, available in red, red-orange and amber, fill the need for mid-power illumination capabilities between Avago Technologies' conventional PLCC-4 products, operating at up to 200 mW power levels, and Philips Lumileds Lighting's Luxeon LED light sources that operate at power levels of 1 watt and higher. The Power PLCC-4 package can be driven at high current due to its superior design, and is able to dissipate the heat more efficiently than conventional PLCC-2 SMT LEDs. It also offers much higher quality and reliability and superior mechanical characteristics to reduce tombstoning, prevent delamination and improve pick-and-place assembly.

The reliability and performance characteristics of these mid-power LEDs, such as their  $-40^{\circ}\text{C}$  to  $+100^{\circ}\text{C}$  operating temperature range, make them uniquely suitable for use in harsh conditions such as automotive applications, and in electronic signs and signals. To facilitate easy pick and place assembly, the LEDs are packed in EIA-compliant tape and reel. Every reel is shipped in single intensity and color bin (except for red) to provide close uniformity.

These LEDs are compatible with both IR solder reflow and through-the-wave (TTW) soldering processes.

### Features and Benefits

- Industry Standard PLCC-4 (plastic leaded chip carrier) form factor
- High reliability Power PLCC-4 package
- Mid-power intensity with optimum flux performance using TS AlInGaP (transparent substrate aluminum indium gallium phosphide) dice technologies
- Available in red, red orange and amber colors
- High optical efficiency
- Higher ambient temperature at the same current possible compared to PLCC-2
- Super wide 120-degree viewing angle
- Well-suited for backlighting applications
- Supplied in EIA-standard 8 mm carrier tape on 7 inch reel
- Compatible with both IR and TTW soldering processes

### Applications

- Interior automotive
  - Instrument panel backlighting
  - Central console backlighting
  - Navigation and audio system lighting
  - Push button backlighting
- Exterior automotive
  - Turn signals
  - Side repeater lamps
  - CHMSLs (center high-mounted stop light)
  - Rear combination lamps
  - Puddle lights
- Electronic signs and signals
  - Channel lettering
  - Contour lighting
  - Indoor variable message signs
- Office automation, home appliances, industrial equipment
  - Front panel backlighting
  - Push button backlighting
  - Display backlighting

## Device Selection Guide

### Envisium 0.25W Power PLCC-4 Surface Mount LED

Part Number	Color	Typ. Dominant Wavelength $\lambda_D$ (nm) <sup>1</sup>	Typ. Viewing Angle $2\theta_{1/2}$ (°) <sup>2</sup>	Intensity Bin	Min. IV (mcd)	Max. IV (mcd)	Total Flux $\Phi_V$ (lm) <sup>4,5</sup> Typ.	Typ. VF (V)	Test Current (mA)
ASMC-PRB9-TV005	AllnGaP Red	630.0	120	V1	630.00	1000.00	2600.00	2.8	50
		630.0	120	V2	790.00	1260.00	3300.00	2.8	50
		630.0	120	W1	1000.00	1600.00	–	2.8	50
ASMC-PHB9-TW005	AllnGaP Red Orange	617.0	120	W1	1000.00	1600.00	4300.00	2.8	50
		617.0	120	W2	1200.00	2020.00	5000.00	2.8	50
		617.0	120	X1	1580.00	2500.00	–	2.8	50
ASMC-PAB9-TV005	AllnGaP Amber	592.0	120	V1	630.00	1000.00	3000.00	2.8	50
		592.0	120	V2	790.00	1260.00	3800.00	2.8	50
		592.0	120	W1	1000.00	1600.00	–	2.8	50

**Notes:**

1. The dominant wavelength,  $\lambda_D$ , is derived from the CIE Chromaticity Diagram and represents the color of the device.
2.  $\theta_{1/2}$  is the off-axis angle where the luminous intensity is 1/2 the peak intensity.
3. The luminous intensity,  $I_v$ , is measured at the mechanical axis of the lamp package. The actual peak of the spatial radiation pattern may not be aligned with this axis.
4.  $\Phi$  is the total luminous flux output as measured with an integrating sphere after the device has stabilized.
5. Flux tested at mono pulse conditions.

### Envisium 0.5W Power PLCC-4 Surface Mount LED

Part Number	Color	Typ. Dominant Wavelength $\lambda_D$ (nm) <sup>1</sup>	Typ. Viewing Angle $2\theta_{1/2}$ (°) <sup>2</sup>	Flux Bin	Min. Flux (lm)	Max. Flux (lm)	Typ. Vf (V)	Test Current (mA)	Dice Technology
ASMC-QAB2-TAC0E	Amber	593.5	120	A	4.3	5.5	2.64	150	AllnGaP
				B	5.5	7.0		150	
				C	7.0	9.0		150	
ASMC-QHB2-TCDOE	Red Orange	619.3	120	C	7.0	9.0	2.64	150	AllnGaP
				D	9.0	11.5		150	

**Notes:**

1. The dominant wavelength,  $\lambda_D$ , is derived from the CIE Chromaticity Diagram and represents the color of the device.
2.  $\theta_{1/2}$  is the off-axis angle where the luminous intensity is 1/2 the peak intensity.
3. The luminous intensity,  $I_v$ , is measured at the mechanical axis of the lamp package. The actual peak of the spatial radiation pattern may not be aligned with this axis.
4.  $\Phi$  is the total luminous flux output as measured with an integrating sphere after the device has stabilized.
5. Flux tested at mono pulse conditions.

### Envisium 0.25W Power PLCC-4

#### Intensity Bin Select ( $X_2X_3$ )

An individual reel will contain parts from one half bin only

$X_2X_3$	Min. $I_v$ Bin
0	Full Description
3	3 half bins starting from $X_21$
4	4 half bins starting from $X_21$
5	5 half bins starting from $X_21$
7	3 half bins starting from $X_21$
8	4 half bins starting from $X_21$
9	5 half bins starting from $X_21$

#### Intensity Bin Limits and Typical Flux

Bin ID	Min. (mcd)	Max. (mcd)
V1	715.00	900.00
V2	900.00	1125.00
W1	1125.00	1400.00
W2	1400.00	1800.00
X1	1800.00	2240.00
X2	2240.00	2850.00

Tolerance of each bin limit =  $\pm 12\%$

# LED Solutions

## Color Bin Select (X<sub>4</sub>)

An individual reel will contain parts from one half bin only

X <sub>4</sub>	
0	Full Distribution
A	1 and 2 only
B	2 and 3 only
C	3 and 4 only
D	4 and 5 only
E	5 and 6 only
F	6 and 7 only
G	1, 2 and 3 only
H	2, 3 and 4 only
J	3, 4 and 5 only
K	4, 5 and 6 only
L	5, 6 and 7 only
M	1, 2, 3 and 4 only
N	2, 3, 4 and 5 only
P	3, 4, 5 and 6 only
Q	4, 5, 6 and 7 only
R	1, 2, 3, 4 and 5 only
S	2, 3, 4, 5 and 6 only

## Color Bin Limits

Amber/ Yellow	Min. (nm)	Max. (nm)
1	582.0	584.5
2	584.5	587.0
3	587.0	589.5
4	589.5	592.0
5	592.0	594.5
6	594.5	597.0

Red Orange	Min. (nm)	Max. (nm)
1	611.0	616.0
2	616.0	620.0

Red	Min. (nm)	Max. (nm)
Full Distribution		

Tolerance of each bin limit = ±1 nm

## Packaging Option (X<sub>9</sub>)

Option	Test Current	Package Type	Reel Size
5	50 mA	Top Mount	7 inch

## Envisium 0.5W Power PLCC-4 Color Bin Select (X<sub>4</sub>)

An individual reel will contain parts from one half bin only

X <sub>4</sub>	
0	Full Distribution
A	1 and 2 only
B	2 and 3 only
C	3 and 4 only
D	4 and 5 only
E	5 and 6 only
G	1, 2 and 3 only
H	2, 3 and 4 only
J	3, 4 and 5 only
K	4, 5 and 6 only
M	1, 2, 3 and 4 only
N	2, 3, 4 and 5 only
P	3, 4, 5 and 6 only
R	1, 2, 3, 4 and 5 only
S	2, 3, 4, 5 and 6 only
Z	Special Color Bin

## Flux Bin Select (X<sub>2</sub>X<sub>3</sub>)

An individual reel will contain parts from one half bin only

X <sub>2</sub>	Min. Flux Bin
X <sub>3</sub>	Max. Flux Bin

## Flux Bin Limits

BIN ID	Min. (lm)	Max. (lm)
A	4.30	5.50
B	5.50	7.00
C	7.00	9.00
D	9.00	11.50
E	11.50	15.00
F	15.00	19.50
G	19.50	25.50
H	25.50	33.00
J	33.00	43.00
K	43.00	56.00
L	56.00	73.00

Tolerance of each bin limit = ±0.12%

## Color Bin Limits

Amber/ Yellow	Min. (nm)	Max. (nm)
2	583.0	586.0
3	586.0	589.0
4	589.0	592.0
5	592.0	595.0
6	595.0	598.0

Red Orange	Min. (nm)	Max. (nm)
1	611.0	616.0
2	616.0	620.0
3	620.0	625.0

## V<sub>f</sub> Binning

Bin	Min.	Max.
2D	2.35	2.50
2E	2.50	2.65
2F	2.65	2.80
2G	2.80	2.95
2H	2.95	3.10
2J	3.10	3.25

Tolerance of each bin limit = ±0.1V

## Packaging Option (X<sub>9</sub>)

Option	Test Current	Package Type	Reel Size
E	150 mA	Top Mount	7 inch

# LED Solutions

## Package Dimensions

### Envisium 0.25W Power PLCC-4

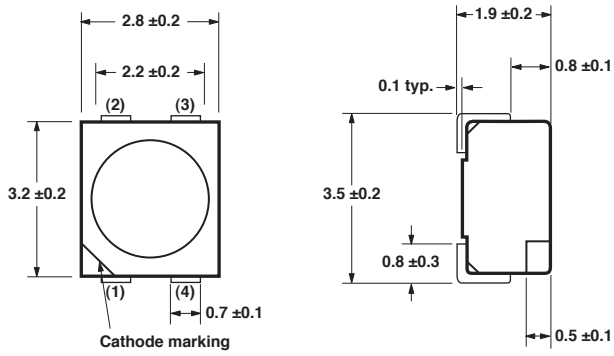

Note: All dimensions in mm

Envisium Power PLCC-4	
1	Cathode
2	Common Anode
3	Cathode
4	Cathode

### Envisium 0.5W Power PLCC-4

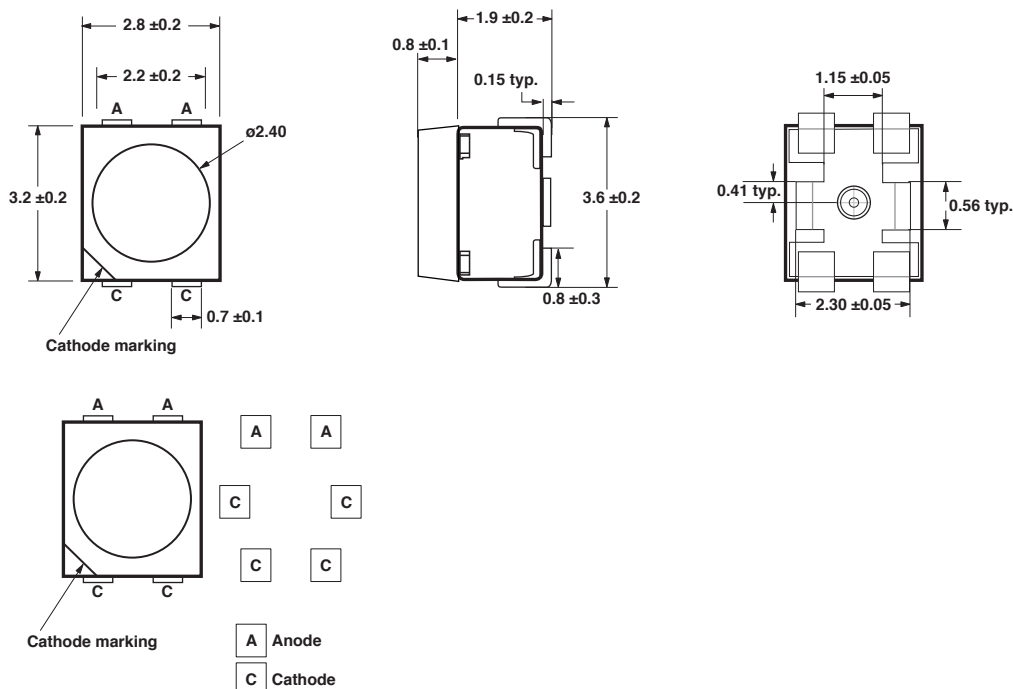

## Moonstone™ High Power LEDs

### Description

High Power LED is a high-performance, energy-efficient device that can handle high-thermal and high-driving current. The exposed pad design has excellent heat transfer from the package to the motherboard. The low-profile package design is suitable for a wide variety of applications, especially where height is a constraint. The package is compatible with the SMT reflow soldering process and manual soldering. This will give more freedom and flexibility to the light source designer.

### Features and Benefits

- Available in White, Blue, Green, Red and Amber color
- Energy efficient
- Exposed pad for excellent heat transfer
- Suitable for SMT process
- High-current operation
- Long operation life
- Wide viewing angle
- Silicone encapsulation
- Available in emitter and module

### Typical Applications

- Portable (flashlight, bicycle headlight)
- Reading light
- Architectural lighting
- Garden lighting
- Decorative lighting
- Street lighting
- Retail lighting
- Contour lighting
- Sign backlighting

### Specifications

- InGaN and AlInGaP technology
  - InGaN: 3.6 V, 350 mA (typical)
  - AlInGaP: 2.4 V, 350 mA (typical)
- 120° viewing angle

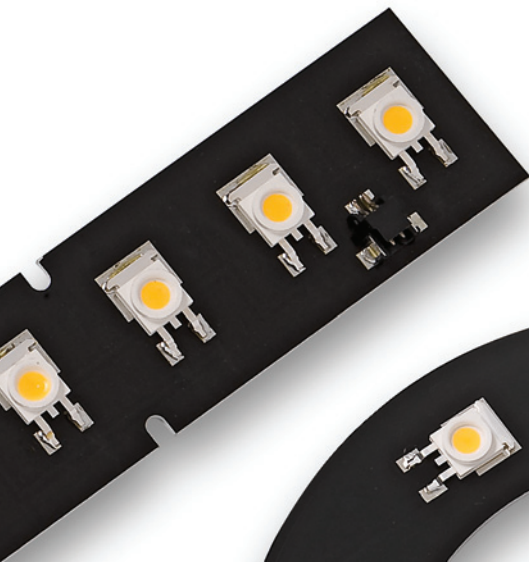

# LED Solutions

## Moonstone 0.5W LEDs

Part Number	Color	Encapsulation Type	Color Temperature (K)	Viewing Angle $2\theta_{1/2}$ (°)	Luminous Flux, $\Phi_v$ (lm)			Metal Slug	Forward Voltage $V_f$ (V)	Test Current (mA)
					Min.	Typ.	Max.			
ASMT-MW60-NFH00	InGaN Cool White	Clear	4000-10000	110	19.5	30	43	Non-Isolated	3.5	150
ASMT-MW62-NFH00	InGaN Cool White	Clear	4000-10000	110	19.5	30	43	Isolated	3.5	150
ASMT-MY60-NEG00	InGaN Warm White	Clear	2600-4000	110	15	25	33	Non-Isolated	3.5	150
ASMT-MY62-NEG00	InGaN Warm White	Clear	2600-4000	110	15	25	33	Isolated	3.5	150
ASMT-MWH0-NFH00	InGaN Cool White	Diffused	4000-10000	120	19.5	25	43	Non-Isolated	3.5	150
ASMT-MWH2-NFH00	InGaN Cool White	Diffused	4000-10000	120	19.5	25	43	Isolated	3.5	150
ASMT-MYH0-NEG00	InGaN Warm White	Diffused	2600-4000	120	15	20	33	Non-Isolated	3.5	150
ASMT-MYH2-NEG00	InGaN Warm White	Diffused	2600-4000	120	15	20	33	Isolated	3.5	150

## Moonstone 1W LEDs

Part Number	Color	Dominant Wavelength $\lambda_b$ (nm)	Viewing Angle $2\theta_{1/2}$ (°)	Luminous Flux, $\Phi_v$ (lm)			Forward Voltage $V_f$ (V)	Test Current (mA)
				Min.	Typ.	Max.		
ASMT-MG00-NGJ00	InGaN Green	525	120	25.5	40	56.0	3.6	350
ASMT-MB00-NAE00	InGaN Blue	467	120	5.5	10	19.5	3.6	350
ASMT-MA00-AGH00	AllInGaP Amber	590	120	25.5	35	43	2.4	350
ASMT-MR00-AGH00	AllInGaP Red	625	120	25.5	35	43	2.4	350
ASMT-MR00-AHJ00	AllInGaP Red	625	120	33	40	56	2.4	350

## Moonstone 1W White LEDs

Part Number	Color	Color Temperature (K)	Viewing Angle $2\theta_{1/2}$ (°)	Luminous Flux, $\Phi_v$ (lm)			Forward Voltage $V_f$ (V)	Test Current (mA)
				Min.	Typ.	Max.		
ASMT-MW00-NHJ00	InGaN Cool White	4000-10000	110	33	45	56	3.6	350
ASMT-MW00-NJK00	InGaN Cool White	4000-10000	110	43	55	73	3.6	350
ASMT-MW00-NKK00	InGaN Cool White	4000-10000	110	56	60	73	3.6	350
ASMT-MW09-NKL00	InGaN Cool White	4000-10000	120	56	80	95	3.6	350
ASMT-MW09-NLL00	InGaN Cool White	4000-10000	120	73	80	95	3.6	350
ASMT-MY00-NJK00	InGaN Warm White	2600-4000	110	43	50	73	3.6	350

## Moonstone LED Modules

Part Number	Color	Number of LEDs	Power (W)	Module Type	Color Temperature (K)	Viewing Angle $2\theta_{1/2}$ (°)	Luminous Flux, $\Phi_v$ (lm)			Forward Voltage $V_f$ (V)	Test Current (mA)	Driving Method
							Min.	Typ.	Max.			
ASMT-MAA0-AGH00	AllInGaP Amber	1	1	Star I	590	120	25.5	35	43	2.4	350	Current
ASMT-MRA0-AGH00	AllInGaP Red	1	1	Star I	625	120	56	35	43	2.4	350	Current
ASMT-MRA0-AHJ00	AllInGaP Red	1	1	Star I	625	120	33	40	56	2.4	350	Current
ASMT-MBA0-NAE00	InGaN Blue	1	1	Star I	467	120	5.5	10	19.5	3.6	350	Current
ASMT-MGA0-NGJ00	InGaN Green	1	1	Star I	525	120	25.5	40	73	3.6	350	Current
ASMT-MAK0-AGH00	AllInGaP Amber	1	1	Star II	590	120	25.5	35	43	2.4	350	Current
ASMT-MRK0-AGH00	AllInGaP Red	1	1	Star II	625	120	56	35	43	2.4	350	Current
ASMT-MRK0-AHJ00	AllInGaP Red	1	1	Star II	625	120	33	40	56	2.4	350	Current
ASMT-MBK0-NAE00	InGaN Blue	1	1	Star II	467	120	5.5	10	19.5	3.6	350	Current
ASMT-MGK0-NGJ00	InGaN Green	1	1	Star II	525	120	25.5	40	73	3.6	350	Current

# LED Solutions

## Moonstone White LED Modules

Part Number	Color	Number of LEDs	Power (W)	Module Type	Color Temperature (K)	Viewing Angle $2\theta_{1/2}$ (°)	Luminous Flux, $\Phi_v$ (lm)			Forward Voltage $V_f$ (V)	Test Current (mA)	Driving Method
							Min.	Typ.	Max.			
ASMT-MWA0-NKK00	InGaN Cool White	1	1	Star I	4000-10000	110	56	60	73	3.6	350	Current/Voltage
ASMT-MYA0-NJK00	InGaN Warm White	1	1	Star I	2600-4000	110	43	50	73	3.6	350	Current/Voltage
ASMT-MWK0-NKK00	InGaN Cool White	1	1	Star II	4000-10000	110	56	60	73	3.6	350	Current/Voltage
ASMT-MYK0-NJK00	InGaN Warm White	1	1	Star II	2600-4000	110	43	50	73	3.6	350	Current/Voltage
ADJD-WM00-NKKZ0	InGaN Cool White	3	4	Strip	4500-5600	-	-	180	-	-	350	Current
ADJD-WM01-NKKZ0	InGaN Cool White	3	4	Strip	4500-5600	-	-	180	-	12	-	Voltage
ADJD-YM00-NJJZ0	InGaN Warm White	3	4	Strip	2600-3000	-	-	150	-	-	350	Current
ADJD-YM01-NJJZ0	InGaN Warm White	3	4	Strip	2600-3000	-	-	150	-	12	-	Voltage
ADJD-WM10-NKKZ0	InGaN Cool White	4	5	Strip	4500-5600	-	-	240	-	-	350	Current
ADJD-YM10-NJJZ0	InGaN Warm White	4	5	Strip	2600-3000	-	-	200	-	-	350	Current
ADJD-WM21-NKKZ0	InGaN Cool White	6	8	Strip	4500-5600	-	-	360	-	12	-	Voltage
ADJD-YM21-NJJZ0	InGaN Warm White	6	8	Strip	2600-3000	-	-	300	-	12	-	Voltage
ADJD-WMRO-NKKZ0	InGaN Cool White	7	9	Round	4500-5600	-	-	420	-	-	350	Current
ADJD-YMRO-NJJZ0	InGaN Warm White	7	9	Round	2600-3000	-	-	350	-	-	350	Current
ADJD-YMR3-NKKZ0	InGaN Cool White	8	10	Ring	4500-5600	-	-	480	-	-	700	Current
ADJD-YMR3-NJJZ0	InGaN Warm White	8	10	Ring	2600-3000	-	-	400	-	-	700	Current
ADJD-WM30-NKKZ0	InGaN Cool White	9	12	Strip	4500-5600	-	-	540	-	-	1050	Current
ADJD-YM30-NJJZ0	InGaN Warm White	9	12	Strip	2600-3000	-	-	450	-	-	1050	Current
ADJD-WM40-NKKZ0	InGaN Cool White	12	15	Strip	4500-5600	-	-	720	-	-	700	Current
ADJD-YM40-NJJZ0	InGaN Warm White	12	15	Strip	2600-3000	-	-	600	-	-	700	Current

### Notes:

1. Typical values at  $T_j = 25^\circ\text{C}$ .
2. All values are typical values unless otherwise specified.
3.  $\Phi_v$  is the total luminous flux output as measured with an integrating sphere at mono pulse condition.
4. Flux tolerance is  $\pm 15\%$ .
5. The dominant wavelength,  $\lambda_{pr}$ , is derived from the CIE Chromaticity Diagram and represents the color of the device.
6.  $\theta_{1/2}$  is the off-axis angle where the luminous intensity is  $1/2$  the peak intensity.

# LED Solutions

## Package Dimensions Moonstone LED Emitters

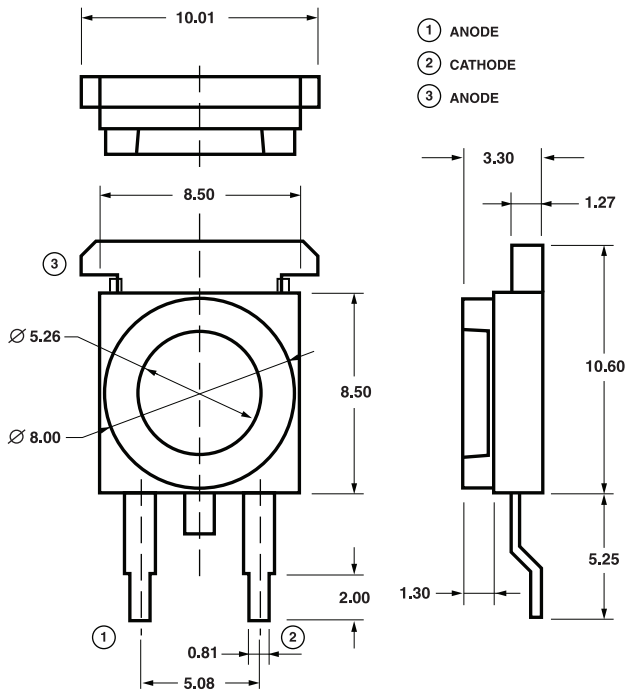

### Notes:

1. All Dimensions in millimeters.
2. Tolerance is  $\pm 0.1$  mm unless otherwise specified.

# LED Solutions

## Package Dimensions Moonstone LED Light Strips

ADJD-xM00 (3 LEDs)

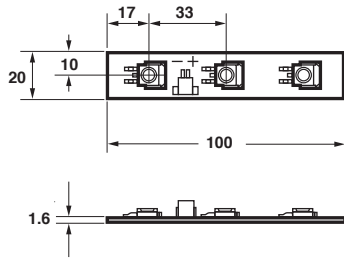

ADJD-xM30 (9 LEDs)

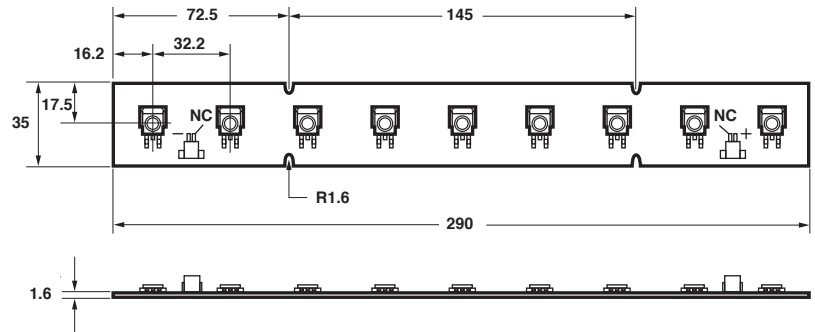

ADJD-xM01 (3 LEDs)

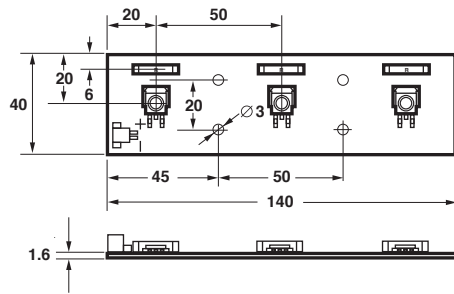

ADJD-xM40 (12 LEDs)

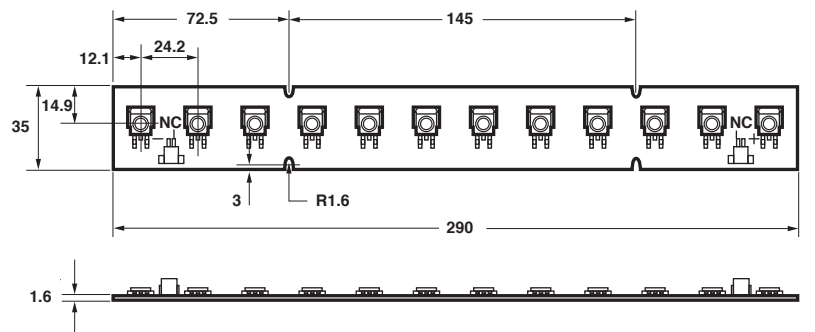

ADJD-xM10 (4 LEDs)

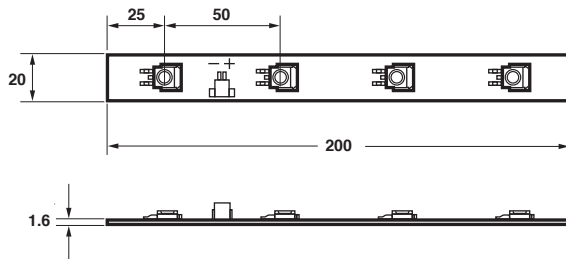

ADJD-xM21 (6 LEDs)

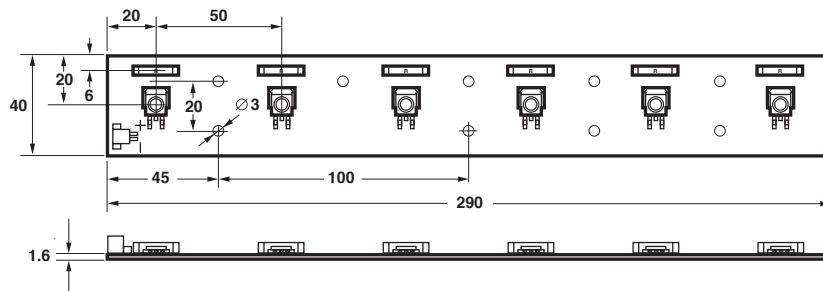

NOTES:  
ALL DIMENSIONS IN MILLIMETERS  
TOLERANCE IS  $\pm 0.1$ MM UNLESS OTHERWISE SPECIFIED

# LED Solutions

## Package Dimensions Moonstone LED Light Strips

ADJD-xMR0 (7 LEDs)

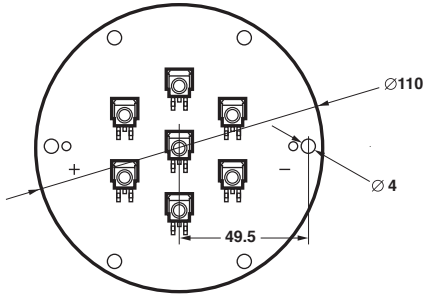

ADJD-xMR3 (8 LEDs)

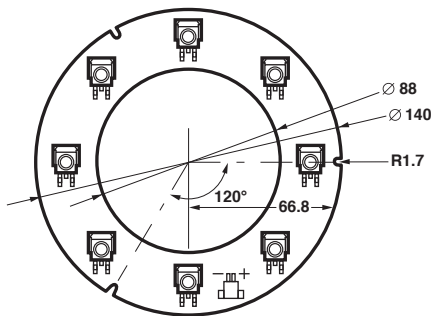

Moonstone Star I LED Modules

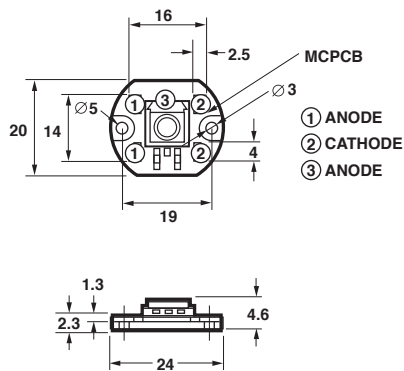

Moonstone Star II LED Modules

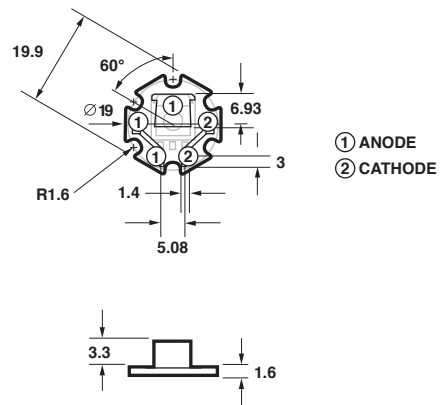

NOTES:  
DIMENSIONS IN MILLIMETERS  
TOLERANCE IS  $\pm 0.1$ MM UNLESS OTHERWISE SPECIFIED



## Moonstone™ High Power RGB LED Modules

### Description

Avago Technologies' new High Power RGB LED Module is the industry's first Plug and Play RGB LED Light Source which can be operated at high driving current. The built-in heat sink and the mechanical mounting features simplify the thermal management of a lighting solution. This enables effective heat transfer and maintain LED junction below maximum allowed temperature.

The footprint of the top emitting package is 100mm x 18mm x 3.6mm with aperture of 96mm x 6mm. The footprint of side emitting package is 100mm x 18mm x 8mm with aperture of 96mm x 4.6mm. The reflector cavity design maximized the light extraction as well as maximized the color mixing to produce the required color. Together with closely pitched LED dice, the color mixing is best of its class.

### Features and Benefits

- High flux output
- Choice of top emitting or side emitting
- Compact footprint
- Integrated heatsink
- Red, Green & Blue color premix in the reflector cavity to produce required color
- Silicone encapsulation
- Plug and play mechanical mounting and electrical connection (connector interface)
- Ease of stacking horizontally and vertically
- Simplified thermal management
- Extra long product life
- Fully serviceable due to ease of mounting and demounting.

### Typical Applications

- Decorative lighting
- Architectural lighting
- Specialty lighting
- Backlighting
- Commercial lighting

### Product Specifications

Part Number	Orientation	With Cable
ADJD-MJ50	Top Emitting	No
ADJD-MJ51	Top Emitting	Yes
ADJD-MJ60	Side Emitting	No
ADJD-MJ61	Side Emitting	Yes

### Technical Specifications

Color	Wavelength (nm)	Current (I <sub>r</sub> )	Voltage (V <sub>r</sub> )	Viewing Angle (°)	Luminous Flux (lm)
AllInGaP Red	617	300	29	110	200
InGaN Green	530	150	35	110	125
InGaN Blue	457	150	35	110	30
InGaN Green	530	150	35	110	125

## Package Dimensions

### ADJD-MJ50/MJ51 (Top Emitting)

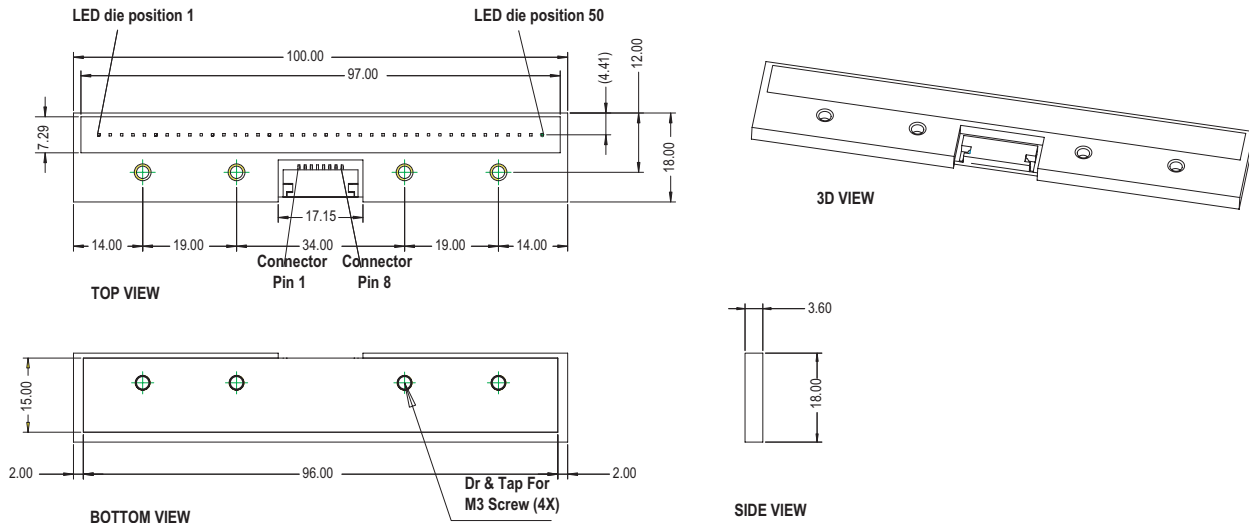

### ADJD-MJ60/MJ61 (Side Emitting)

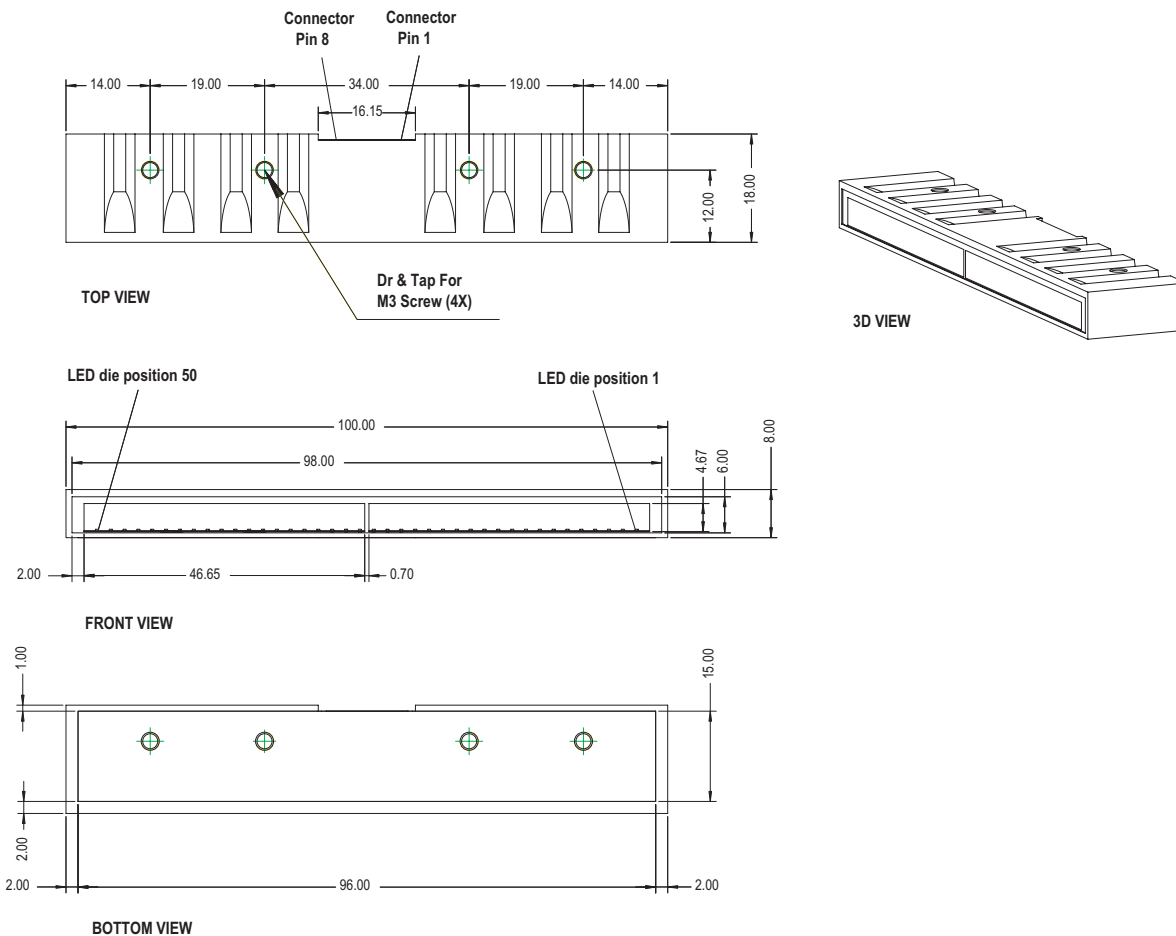

**Notes:**

1. All Dimensions are in millimeters.
2. Tolerance =  $\pm 0.20$  mm unless otherwise specified.



## Standard Through-hole Lamps

### Description

Avago Technologies offers three types of technology-based LEDs. GaP-based technologies are suitable for low to moderate light output requirements. AlInGaP and InGaN product offerings are suitable for high brightness needs. Through-hole LEDs are offered in a variety of packages such as 3 mm, 4 mm, 5 mm, rectangular, bicolor, integrated resistors in standard and low current options.

These devices are molded from advanced optical grade epoxy, which provide superior high temperature performance and excellent moisture resistance.

Through-hole LEDs are suitable for all applications requiring backlighting and status indication. Consumer electronics and automotive interiors use LEDs to add value to their products. Low power consumption, high reliability and a broad range of colors and packages are just a few reasons why.

### Features and Benefits

- Excellent product quality and reliability
- Wide range of products
- Competitive pricing
- Wide operating temperature range
  - With minor electrical/optical changes
- Lower power consumption
  - High efficiency, low drive currents and low driving voltages required
- High reliability
  - No replacement for life of equipment
- High reliability for AlInGaP lamps compared to TS AlGaAs at equivalent pricing and high brightness
  - No replacement for life of equipment with 100 or 1000 hours projected life
- Thin, light weight and robust packaging
  - Excellent performance even under vibration and mechanical shock
- Different material technologies available in standard GaP LED lamps
  - Choice of colors (560 nm – 626 nm): Green, Yellow, Amber, Orange and Red
- Five colors available with high luminous intensity in AlInGaP LED lamps
  - Amber (590 nm), Red (626 nm), deep Red (635 nm), Orange (605 nm) and Red-Orange (615 nm)
- Four colors available with high luminous intensity in InGaN LED lamps
  - Blue (470 nm), Green (527 nm), Bluish Green (500 nm) and White
- Several packaging options
  - Different sizes with a clear or diffused lens, several lead configurations and different spatial radiation patterns available in bulk, ammo-pack, right angle housing and tape and reel

### Typical Applications

- Consumer
  - ovens, washers, etc.
  - audio, hi-fi and electrical appliances
  - gaming and vending machines
  - electronic toys and games
- Industrial
  - sensors
  - instruments
  - measurement equipment
- Automotive and Other
  - automotive interior
  - exercise equipment
  - medical equipment
  - front panel industrial equipment











# LED Indicators and Displays

## Standard Through-hole LED Lamps

Part Number	Color	Dominant Wavelength (nm)	Viewing Angle	Lens	Intensity		Vf Typ. (V)	Test Current (mA)	2 Intensity Bin Selection
					Min. (mcd)	Typ. (mcd)			
<b>3 mm (T1) LED Lamps — Standard Current</b>									
HLMP-1301-G0002	GaP Red	626	60°	Tinted, Diffused	8.6	11	1.9	10	n/a
HLMP-1321	GaP Red	626	45°	Tinted, Non-diffused	8.6	30	1.9	10	n/a
HLMP-1340	GaP Red	626	45°	Micro-tinted, Non-diffused	8.6	30	1.9	20	n/a
HLMP-1401-E0000	GaP Yellow	585	60°	Tinted, Diffused	3.6	6	2	10	E, F
HLMP-1440	GaP Yellow	585	45°	Micro-tinted, Non-diffused	23.5	45	2.1	20	H, I
HLMP-1503	GaP Green	569	60°	Tinted, Diffused	4.2	8.5	2	10	D, E
HLMP-1521	GaP Green	569	45°	Tinted, Non-diffused	6.7	22	2.1	10	n/a
HLMP-1540	GaP Green	569	45°	Untinted, Non-diffused	27.3	45	2.2	20	I, J
HLMP-K101	AlGaAs Red	637	60°	Tinted, Diffused	22	45	1.8	20	n/a
HLMP-K105	AlGaAs Red	637	45°	Untinted, Non-diffused	35.2	65	1.8	20	n/a
HLMP-K640	GaP Green	560	45°	Untinted, Non-diffused	4.2	21	2.2	20	n/a
HLMP-KB45-A0000	GaN Blue	462	40°	Untinted, Non-diffused	30	45	4	20	n/a
<b>3 mm (T1) LED Lamps — Autoinsertable</b>									
HLMP-NG05	AllInGaP Red	626	45°	Micro-tinted, Non-diffused	90.2	—	1.90	20	n/a
HLMP-NG07	AllInGaP Red	626	60°	Micro-tinted, Non-diffused	90.2	—	1.90	20	n/a
HLMP-NL06	AllInGaP Amber	590	60°	Micro-tinted, Non-diffused	90.2	—	2.02	20	n/a
HLMP-NS30-J0000	InGaN Blue	470	30°	Untinted, Non-diffused	240	550	3.6	20	n/a
HLMP-NM31-R0000	InGaN Green	529	30°	Untinted, Non-diffused	1500	2800	3.3	20	n/a
<b>3 mm (T1) 5V, 12V Integrated Resistor LED Lamps</b>									
HLMP-1621 <sup>[1]</sup>	GaP Yellow	585	60°	Tinted, Diffused	2.2	8	8	—	n/a
HLMP-1640-B00A2 <sup>[2]</sup>	GaP Green	589	60°	Tinted, Diffused	1.6	8	8	—	n/a
<b>Notes: 1. Operating Voltage = 12V. 2. Operating Voltage = 5V.</b>									
<b>5 mm (T1 3/4) LED Lamps — Standard Current</b>									
HLMP-3301	GaP Red	626	60°	Tinted, Diffused	5.4	7	1.9	10	F, G
HLMP-3401	GaP Yellow	585	60°	Tinted, Diffused	5.7	8	2	10	E, F
HLMP-3507	GaP Green	569	60°	Tinted, Diffused	4.2	5.2	2.1	10	E, F
HLMP-3950	GaP Green	569	24°	Micro-tinted, Non-diffused	111.7	265	2.2	20	n/a
HLMP-C008-U0000	AllInGaP Red	626	8°	Untinted, Non-diffused	2900	6000	1.9	20	n/a
HLMP-C025-P0000	AllInGaP Red	626	25°	Untinted, Non-diffused	500	1000	1.9	20	n/a
HLMP-C208-S0000	AllInGaP Amber	590	8°	Untinted, Non-diffused	2600	3000	1.9	20	n/a
HLMP-C225-O0000	AllInGaP Amber	590	25°	Untinted, Non-diffused	450	800	1.9	20	n/a
HLMP-C608-R0000	AllInGaP Red	635	8°	Untinted, Non-diffused	1000	2000	1.9	20	n/a
HLMP-C625-P0000	AllInGaP Red	635	25°	Untinted, Non-diffused	500	700	1.9	20	n/a
HLMP-DB25-B0000	GaN Blue	462	25°	Untinted, Non-diffused	40	100	4	20	n/a
HLMP-DM25-J0000	InGaN Green	527	25°	Untinted, Non-diffused	240	970	3.8	20	n/a
HLMP-DS25-F0000	InGaN Blue	470	25°	Untinted, Non-diffused	110	260	3.6	20	n/a
<b>5 mm (T1 3/4) LED Lamps — Low Current</b>									
HLMP-4700	GaP Red	626	50°	Tinted, Diffused	1.3	2.3	1.8	2	n/a
HLMP-4719	GaP Yellow	585	50°	Tinted, Diffused	0.9	2.1	1.9	2	n/a
HLMP-4740	GaP Green	569	50°	Tinted, Diffused	1	2.3	1.8	2	n/a
HLMP-D150	AlGaAs Red	637	65°	Tinted, Diffused	1.3	3	1.6	1	n/a

# LED Indicators and Displays

## Standard Through-hole Lamps

Part Number	Color	Dominant Wavelength (nm)	Viewing Angle	Lens	Intensity		Vf Typ. (V)	Test Current (mA)	2 Intensity Bin Selection
					Min. (mcd)	Typ. (mcd)			
<b>2 mm x 5 mm Rectangular LED Lamps</b>									
HLMP-S201	 GaP Red	626	110°	Tinted, Diffused	3.4	7.5	1.9	20	n/a
HLMP-S301	 GaP Yellow	585	110°	Tinted, Diffused	2.2	4	2.1	20	n/a
HLMP-S501	 GaP Green	569	110°	Tinted, Diffused	4.2	8	2.2	20	n/a
<b>2mm x 5mm Bicolor Rectangular LED Lamps</b>									
HLMP-0800	 GaP Green	570	100°	Untinted, Diffused	2.6	–	2.2	20	n/a
	 GaP Red	626	100°	Untinted, Diffused	2.1	–	1.9	20	n/a
HLMP-0805	 GaP Green	570	100°	Untinted, Diffused	2.6	–	2.2	20	n/a
	 GaP Yellow	585	100°	Untinted, Diffused	1.4	–	2.1	20	n/a
<b>5 mm (T1 3/4) LED Lamps — Bicolor</b>									
HLMP-4000	 GaP Green	570	65	Untinted, Diffused	4.2	–	2.2	10	n/a
	 GaP Red	626	65	Untinted, Diffused	2.1	–	1.9	10	n/a
HLMP-4015	 GaP Green	570	65	Untinted, Non-Diffused	20	–	2.2	20	n/a
	 GaP Yellow	585	65	Untinted, Non-Diffused	20	–	2.6	20	n/a



## Through-hole LEDs

### Standard Intensity Categories (approx. 2:1 bins)

Bin ID	Iv in mcd	
	Min.	Max.
A	1.0	1.6
B	1.6	2.5
C	2.5	4.0
D	4.0	6.5
E	6.5	10.3
F	10.3	16.6
G	16.6	26.5
H	26.5	42.3
I	42.3	67.7
J	67.7	108.2
K	108.2	173.2
L	173.2	250
M	250	360
N	360	510
O	510	800
P	800	1250
Q	1250	1800
R	1800	2900
S	2900	4700
T	4700	7200
U	7200	11700
V	11700	18000
W	18000	27000

Maximum Tolerance for each bin limit is +/- 18%

Maximum Tolerance for each color bin limit is +/- 0.5 nm

Color Bin	Wavelength (nm)		
	Min.	Max.	
Yellow 	1	582	584.5
	3	584.5	587
	2	587	589.5
	4	589.5	592
	5	592	593.0
<b>Amber </b>			
3	584.5	587	
2	587	589.5	
4	589.5	592	
6	592	594.5	
7	594.5	597	

Bin ID	Iv in mcd		
	Min.	Max.	
Red/Orange 	A	0.6	0.9
	B	0.9	1.5
C	1.5	2.4	
D	2.4	3.8	
E	3.8	6.1	
F	6.1	9.7	
G	9.7	15.5	
H	15.5	24.8	
I	24.8	39.6	
J	39.6	63.4	
K	63.4	101.5	
L	101.5	162.4	
M	162.4	234.6	
N	234.6	340.0	
O	340	540	
P	540	850	
Q	850	1200	
R	1200	1700	
S	1700	2400	
T	2400	3400	
U	3400	4900	
V	4900	7100	
W	8100	10200	
X	10200	14800	
Y	14800	21400	
Z	21400	30900	

Maximum Tolerance for each bin limit is +/- 18%

Maximum Tolerance for each color bin limit is +/- 0.5 nm

# LED Indicators and Displays

## Standard Through-hole Lamps

### Through-hole LEDs

#### Standard Intensity Categories (approx. 2:1 bins)

Colors: Blue (InGaN/GaN)   
InGaN Green 

Bin ID	Iv in mcd	
	Min.	Max.
A	30.0	40.0
B	40.0	50.0
C	50.0	65.0
D	65.0	85.0
E	85.0	110.0
F	110.0	140.0
G	140.0	180.0
H	180.0	240.0
J	240.0	310.0
K	310.0	400.0
L	400.0	520.0
M	520.0	680.0
N	680.0	880.0
P	880.0	1150.0
Q	1150.0	1500.0
R	1500.0	1900.0
S	1900.0	2500.0
T	2500.0	3200.0
U	3200.0	4200.0
V	4200.0	5500.0
W	5500.0	7200.0
X	7200.0	9300.0
Y	9300.0	12000.0
Z	12000.0	16000.0
1	16000.0	21000.0
2	21000.0	27000.0
3	27000.0	35000.0
4	35000.0	45000.0
5	45000.0	59000.0

Tolerance for each bin limit is  $\pm 15\%$ .

Bin ID Color	Wavelength (nm)	
	Min.	Max.
A	1.1	1.8
B	1.8	2.9
C	2.9	4.7
D	4.7	7.6
E	7.6	12.0
F	12.0	19.1
G	19.1	30.7
H	30.7	49.1
I	49.1	78.5
J	78.5	125.7
K	125.7	201.1
L	201.1	289
M	289	417
N	417	680
O	680	1100
P	1100	1800
Q	1800	2700
R	2700	4300
S	4300	6800
T	6800	10800
U	10800	16000
V	16000	25000
W	25000	40000

Maximum Tolerance for each bin limit is  $\pm 18\%$

Maximum Tolerance for each color bin limit is  $\pm 0.5$  nm

Color Bin	Wavelength (nm)	
	Min.	Max.
9	552.5	555.5
8	555.5	558.5
7	558.5	561.5
6	561.5	564.5
5	564.5	567.5
4	567.5	570.5
3	570.5	573.5
2	573.5	576.5

Color Bin	Wavelength (nm)	
	Min.	Max.
1	460.0	464.0
2	464.0	468.0
3	468.0	472.0
4	472.0	476.0
5	476.0	480.0
6	480.0	484.0
Green Color		
1	520.0	530.0
2	530.0	540.0
3	520.0	525.0
4	525.0	530.0
5	530.0	535.0
6	535.0	540.0

Tolerance for each bin limit is  $\pm 2\%$ .

# LED Indicators and Displays

## 3 mm (T1) LED Lamps – Autoinsertable Package

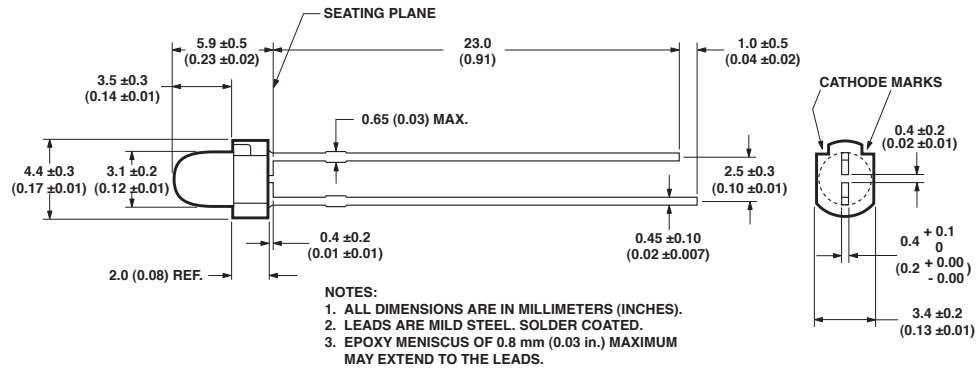

## 5 mm (T1-3/4) LED Lamps - Bicolor

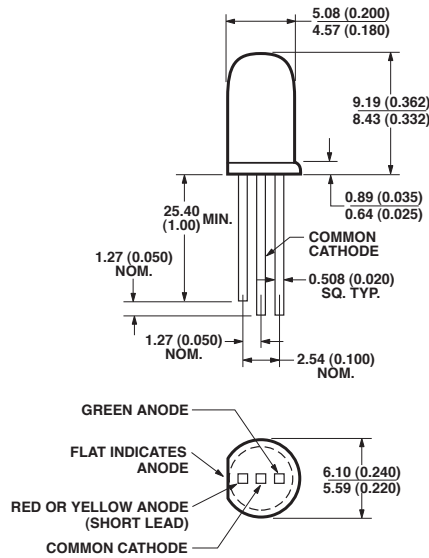

## 3 mm (T1) LED Lamps Package

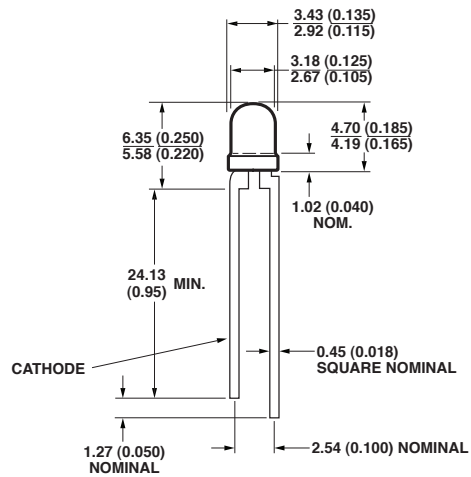

## 5 mm (T1 3/4) LED Lamps Package

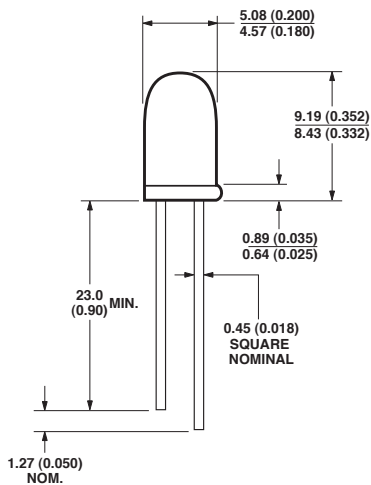

## 2 x 5 mm Rectangular LED Lamps Package

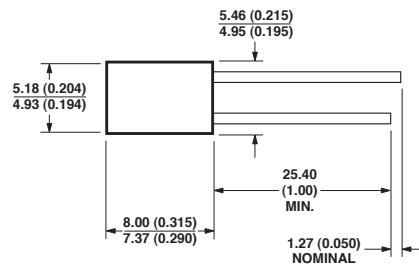

## Subminiature Lamps



### Description

Avago Technologies' Subminiature Lamps are designed for modern printed circuit (PC) boards, replacing through-hole mounted components for many traditional functions with smaller components, sized for closer placement.

Subminiature Lamp components are available in several lead configurations and can be used for top mount, reverse mount, and through-hole applications. The lead configurations are 'Gull Wing'–011 option, 'Yoke Bend'–021 option and 'Z Bend'–031 option. A variety of packages are available, such as flat top, dome and rectangular in standard or low current options.

Besides this, PCB based subminiature lamps are available as well. These lamps come in un-tinted, non-diffused package to cater for various product themes and ease handling applications. The small size, narrow footprint and high brightness make these LEDs excellent for backlighting, status indication and panel illumination applications.

### Features and Benefits

- Excellent product quality
- Wide range of product offering
- Competitive pricing
- Can be used with surface mount or through-hole applications
- High reliability
  - No replacement for life of equipment
- Wide operating temperature range
  - Minor electrical/optical changes
- Lower power consumption
  - High efficiency, low drive currents required, low driving voltages
- Thin, light-weight and robust packaging
  - Excellent performance even under vibration and mechanical shock
- Different thin material technologies available
  - Several colors available in GaP
  - Choice of colors (560 – 626 nm): Green, Yellow, Amber, Orange, Red and Deep Red
  - Three colors available in AlnGaP
    - Amber (590 nm), Red (626 nm) and Orange (605 nm)
  - Two colors available in InGaN
    - Blue (472 nm), Green (526 nm)
- Several lead configuration options
  - Gull-wing, Yoke-bend and Z-bend
- Several Packaging options
  - Different sizes and spatial radiation patterns available in bulk, right angle housing, and tape and reel

### Typical Applications

- Industrial and Communication
  - Front panel and symbol indicator
  - Keypad and push button backlighting
- Consumer
  - CD player, hi-fi audio and electrical appliances
  - Keypad and push button backlighting
- Automotive
  - Dashboard panel and symbol backlighting
  - Car radio indicators

# LED Indicators and Displays

## Domed Subminiature Lamps

Part Number	Color	Dominant Wavelength (nm)	Viewing Angle	Lens	Intensity		Vf Typ. (V)	Test Current (mA)
					Min. (mcd)	Typ. (mcd)		
HLMP-Q106-R00xx	TS AlGaAs Red	644	15°	Untinted, Non-diffused	100	530	1.9	20
HLMA-QG00-S00xx	AllnGaP Red	626	15°	Untinted, Non-diffused	160	500	1.9	20
HLMT-QG00	AllnGaP Red	626	15°	Untinted, Non-diffused	–	800	2	20
HLMP-6300-F00xx	GaP Red	626	90°	Tinted, Diffused	1	10	1.8	10
HLMA-QH00-S00xx	AllnGaP Red-Orange	615	15°	Untinted, Non-diffused	160	500	1.9	20
HLMT-QH00-T00xx	AllnGaP Red-Orange	615	15°	Untinted, Non-diffused	250	800	2	20
HLMA-QJ00	AllnGaP Orange	605	15°	Untinted, Non-diffused	–	500	1.9	20
HLMA-QL00-S00xx	AllnGaP Amber	590	15°	Untinted, Non-diffused	160	500	1.9	20
HLMT-QL00-T00xx	AllnGaP Amber	590	15°	Untinted, Non-diffused	250	1000	2	20
HLMP-6400-F00xx	GaP Yellow	585	90°	Tinted, Diffused	1	9	2	10
HLMP-6500-F00xx	GaP Green	569	90°	Tinted, Diffused	1	7	2.1	10
HLMP-6505-L00xx	GaP Green	569	28°	Untinted, Non-diffused	10	40	2.1	10
HLMP-Q600-F00xx	GaP Emerald Green	560	90°	Tinted, Diffused	1	1.5	2.2	10
HLMP-QB00	InGaN Blue	472	20°	Untinted, Non-diffused	–	400	3.5	20
HLMP-QM00	InGaN Green	526	20°	Untinted, Non-diffused	–	600	3.5	20
<b>Domed Subminiature Lamps — Low Current</b>								
HLMP-Q150-F00xx	AlGaAs Red	637	90°	Tinted, Diffused	1	1.8	1.8	1
HLMP-7000-D00xx	GaP Red	626	90°	Tinted, Diffused	0.4	1	1.4	2
HLMP-7019-D00xx	GaP Yellow	585	90°	Tinted, Diffused	0.4	0.6	1.6	2
HLMP-7040-D00xx	GaP Green	569	90°	Tinted, Diffused	0.4	0.6	1.4	2

## Domed Subminiature Lamps — Resistor

Part Number	Color	Dominant Wavelength (nm)	Viewing Angle	Lens	Intensity		Vf Typ. (V)	Test Current (mA)
					Min. (mcd)	Typ. (mcd)		
HLMP-6600-G00xx	GaP Red	626	90°	Tinted, Diffused	1.6	5	9.6	5
HLMP-6620-F00xx	GaP Red	626	90°	Tinted, Diffused	1	2	3.5	5
HLMP-6700-G00xx	GaP Yellow	585	90°	Tinted, Diffused	1.6	5	9.6	5
HLMP-6720-F00xx	GaP Yellow	585	90°	Tinted, Diffused	1	2	3.5	5
HLMP-6800-G00xx	GaP Green	569	90°	Tinted, Diffused	1.6	5	9.6	5
HLMP-6820-F00xx	GaP Green	569	90°	Tinted, Diffused	1	2	3.5	5
<b>Flat Top Subminiature Lamps</b>								
HLMP-P105-L00xx	AlGaAs Red	637	125°	Untinted, Non-diffused	10	30	1.8	20
HLMA-PG00-N00xx	AllnGaP Red	626	125°	Untinted, Non-diffused	25	75	1.9	20
HLMT-PG00	AllnGaP Red	626	125°	Untinted, Non-diffused	–	150	2	20
HLMP-P205-F00xx	GaP Red	626	125°	Untinted, Non-diffused	1	8	1.8	10
HLMA-PH00-N00xx	AllnGaP Red-Orange	615	125°	Untinted, Non-diffused	25	75	1.9	20
HLMT-PH00-P00xx	AllnGaP Red Orange	615	125°	Untinted, Non-diffused	40	150	2	20
HLMA-PJ00	AllnGaP Orange	605	125°	Untinted, Non-diffused	–	75	2	20
HLMA-PL00-N00xx	AllnGaP Amber	590	125°	Untinted, Non-diffused	25	75	1.9	20
HLMT-PL00-POWxx	AllnGaP Amber	590	125°	Untinted, Non-diffused	40	150	2	20
HLMP-P505-G00xx	GaP Green	569	125°	Untinted, Non-diffused	1	5	2.1	10
HLMP-P605-F00xx	GaP Emerald Green	560	125°	Untinted, Non-diffused	1	1.5	2.2	10
HLMP-PB00	InGaN Blue	472	90°	Untinted, Non-diffused	–	80	3.5	20
HLMP-PM00	InGaN Green	526	90°	Untinted, Non-diffused	–	400	3.5	20
<b>PCB Based Subminiature Lamps</b>								
ASMT-BA20-AS000	AllnGaP Amber	590	15°	Untinted, Non-diffused	180	750	2.0	20
ASMT-BG20-AS000	AllnGaP Green	569	15°	Untinted, Non-diffused	180	650	2.0	20
ASMT-BR20-AS000	AllnGaP Red	626	15°	Untinted, Non-diffused	180	650	2.0	20
ASMT-BB20-NS000	InGaN Blue	468	15°	Untinted, Non-diffused	190	650	3.2	20

# LED Indicators and Displays

Subminiature Lamps are also available in the following options:

Mechanical Option Number	Description
10	Right Angle
11	Tape and Reel, 1500 lamps per reel
12	Gull Wing, Bulk Packaging
21	Yoke Lead, Tape and Reel, 1500 lamps per reel
22	Yoke Lead, Bulk Packaging
31	Z-Bend, Tape and Reel, 1500 lamps per reel
32	Z-Bend, Bulk Packaging

## Surface Mount Subminiature LED Lamps Standard Intensity Categories

Package Universal	Customer Iv in mcd		
	Bin	Min.	Max.
	A	0.1	0.2
	B	0.16	0.32
	C	0.25	0.5
	D	0.4	0.8
	E	0.63	1.25
	F	1	2
	G	1.6	3.2
	H	2.5	5
	J	4	8
	K	6.3	12.5
	L	10	20
	M	16	32
	N	25	50
	P	40	80
	Q	63	125
	R	100	200
	S	160	320
	T	250	500
	U	400	800
	V	630	1250
	W	1000	2000
	X	1600	3200
	Y	2500	5000

Package Universal	Color Bin	Wavelength (nm)		
		Min.	Max.	
InGaN Blue	0	Full dist.		
	1	460	464	
	2	464	468	
	3	468	472	
	4	472	476	
	5	476	480	
InGaN Green	6	480	484	
	0	Full dist.		
	1	520	530	
	2	530	540	
	Emerald Green	9	552	556
		8	555	559
7		558	562	
6		561	565	
Green	5	565	568	
	4	567	571	
	3	570	574	
	2	573	577	
Yellow	1	581.5	585	
	3	584	587.5	
	2	586.5	590	
	4	589	592.5	
	5	591.5	593.5	
	6	591.5	595	
	7	594	597.5	
	Orange	1	596.5	600
2		599	602.5	
3		601.5	604	
4		603.8	608.2	
5		606.8	611.2	
6		609.8	614.2	
7		612.8	617.2	
8		615.8	620.2	
Red Orange	1	617.5	625	
	2	621	628.5	
	3	624.5	632	

# LED Indicators and Displays

## Surface Mount Subminiature LED Lamps Package Dimensions

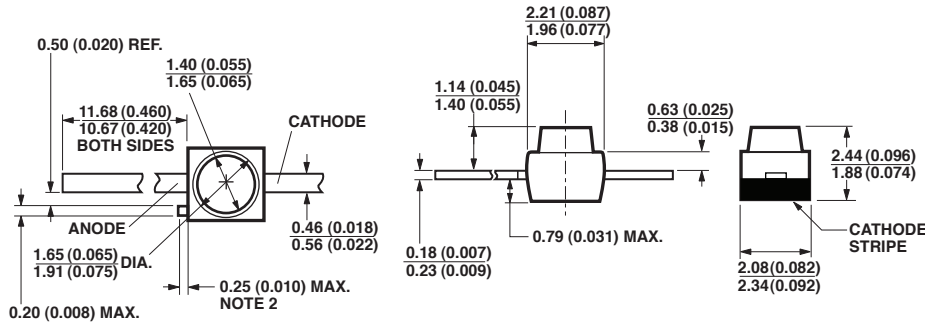

Flat Top Subminiature Lamps

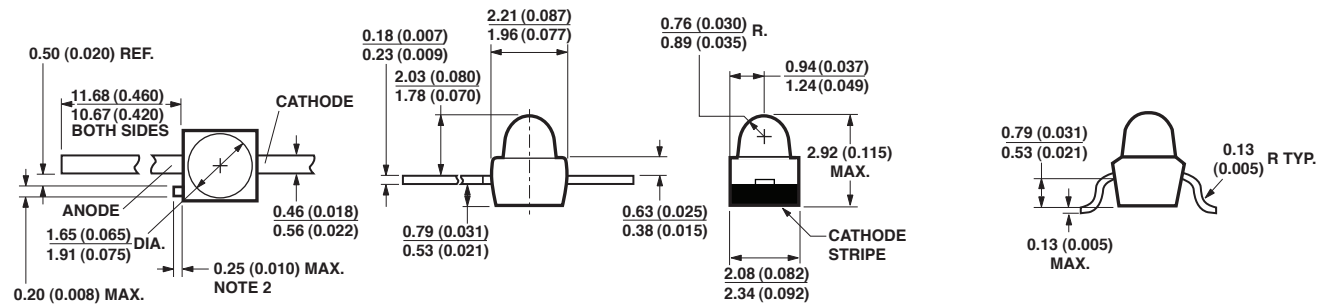

Option 011, 012

- NOTES:  
 1. ALL DIMENSIONS ARE IN MILLIMETRES (INCHES).  
 2. PROTRUDING SUPPORT TAB IS CONNECTED TO CATHODE LEAD.

## Domed Subminiature Lamps

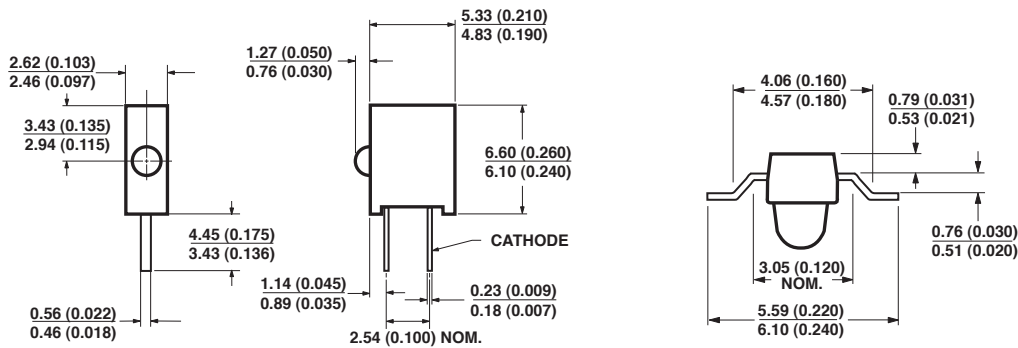

Option 010

Option 031, 032

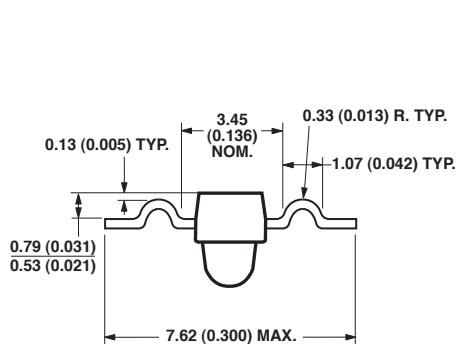

Option 021, 022

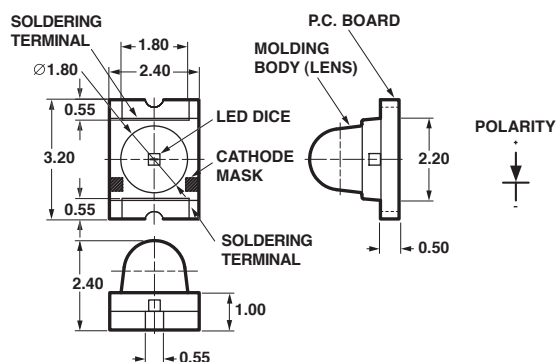

PCB Based Subminiature Lamps



## Surface Mount ChipLEDs

### Description

For applications that require small size, high efficiency and low power consumption, Avago Technologies offers an extensive range of high quality ChipLEDs to meet demands for virtually any surface mount lighting requirement.

Avago Technologies' ChipLEDs are available in standard and high-brightness colors, using Avago Technologies' proven AlGaAs, AlInGaP and InGaN processes to give you the broadest range of colors from a single supplier.

Avago's ChipLEDs use the industry standard footprint, with top-mount, reverse-mount and right-angle-mount packaging options. They also have the lowest profile in the industry and are positioned to support high volume, cost-effective solutions.

ChipLED products are used in a variety of applications including LCD and push button backlighting for cellular phones, white goods and appliances, industrial measurement and control systems, and for symbol lighting and status indication in computer peripherals and consumer goods.

Low power consumption, small size and easy assembly make the ChipLED ideal for backlighting handsets as well as backlighting industrial displays.

### Features and Benefits

- Small size
  - Saves PC board space
- Wide viewing angle
  - Well-suited for backlighting applications
- Intensity and color bin uniformity
  - Can be closely mounted without any intensity variations
- Available in multiple colors
  - Amber, Red, AlGaAs Red, Green, Orange, Yellow, InGaN Blue, InGaN Green, bicolor and tricolor combinations
- Variety of packages and mounting options
  - Top, reverse and right angle auto mountable
- Industry standard footprint
  - No change in existing board layout
- High volume, high reliability
  - Cost-effective solution

### Typical Applications

- Telecommunications
  - Keypad and LCD backlighting for mobile phones, pagers and cordless phones
- Industrial
  - Status and symbol indicator
  - Keypad and LCD backlighting
- Consumer
  - White goods and appliances
- Computer Peripherals
  - Status indicator
- Indoor Full/Mono color sign
- Automotive interior

# LED Indicators and Displays

## Surface Mount ChipLEDs

Part Number	Color	Dominant Wavelength (nm)	Viewing Angle	Lens	Intensity		Vf Typ. (V)	Test Current (mA)
					Min. (mcd)	Typ. (mcd)		
<b>Top Mount 1206 Industrial Footprint with 1.1 mm Height (C150)</b>								
<b>3.2 x 1.6 x 1.1 mm (L x W x H)</b>								
HSMH-C150	AS AlGaAs Red	639	170°	Diffused	7.2	17	1.8	20
HSMD-C150	GaP Orange	604	170°	Diffused	2.8	8	2.2	20
HSMG-C150	GaP Green	572	170°	Diffused	4.5	15	2.2	20
HSMS-C150	GaP Red	626	170°	Diffused	2.8	10	2.1	20
HSMY-C150	GaP Yellow	586	170°	Diffused	2.8	8	2.1	20
HSMQ-C150	InGaN Green	527	140°	Diffused	45	145	3.4	20
HSMR-C150	InGaN Blue	473	140°	Diffused	18	55	3.4	20

Quantity: 3,000 per 7 inch reel

<b>Top Mount 0805 Industrial Footprint with 0.8 mm Height (C170)</b>								
<b>2.0 x 1.25 x 0.8 mm (L x W x H)</b>								
HSMH-C170	AS AlGaAs Red	639	170°	Diffused	7.2	17	1.8	20
HSMD-C170	GaP Orange	604	170°	Diffused	2.8	8	2.2	20
HSMG-C170	GaP Green	572	170°	Diffused	4.5	15	2.2	20
HSMS-C170	GaP Red	626	170°	Diffused	2.8	10	2.1	20
HSMY-C170	GaP Yellow	586	170°	Diffused	2.8	8	2.1	20
HSMA-C170	AS AllnGaP Amber	592	170°	Diffused	28.5	90	1.9	20
HSMC-C170	AS AllnGaP Red	626	170°	Diffused	28.5	90	1.9	20
HSML-C170	AS AllnGaP Orange	605	170°	Diffused	28.5	90	1.9	20
HSMB-C170	GaN Blue	466	170°	Diffused	1.8	6	3.8	20
HSMZ-C170	TS Red	631	170°	Diffused	45	165	2.2	20
HSMN-C170	InGaN Green	525	170°	Diffused	45	120	3.3	20
HSMQ-C170	InGaN Green	527	140°	Diffused	45	145	3.4	20
HSMR-C170	InGaN Blue	473	140°	Diffused	18	55	3.4	20

Quantity: 4,000 per 7 inch reel

<b>Top Mount 0603 Industrial Footprint with 0.8 mm Height (C190)</b>								
<b>1.6 x 0.8 x 0.8 mm (L x W x H)</b>								
HSMH-C190	AS AlGaAs Red	639	170°	Diffused	7.2	17	1.8	20
HSMD-C190	GaP Orange	604	170°	Diffused	2.8	8	2.2	20
HSMG-C190	GaP Green	572	170°	Diffused	4.5	5	2.2	20
HSMS-C190	GaP Red	626	170°	Diffused	2.8	10	2.1	20
HSMY-C190	GaP Yellow	586	170°	Diffused	2.8	8	2.1	20
HSMA-C190	AS AllnGaP Amber	592	170°	Diffused	28.5	90	1.9	20
HSMC-C190	AS AllnGaP Red	626	170°	Diffused	28.5	90	1.9	20
HSML-C190	AS AllnGaP Orange	605	170°	Diffused	28.5	90	1.9	20
HSMZ-C190	TS Red	631	170°	Diffused	45	165	2.2	20
HSMB-C190	GaN Blue	466	170°	Diffused	1.8	6	3.8	20
HSMN-C190	InGaN Green	525	170°	Diffused	45	120	3.3	20
HSMQ-C190	InGaN Green	527	140°	Diffused	45	145	3.4	20
HSMR-C190	InGaN Blue	473	140°	Diffused	18	55	3.4	20

Quantity: 4,000 per 7 inch reel

# LED Indicators and Displays

## Surface Mount ChipLEDs

Part Number	Color	Dominant Wavelength (nm)	Viewing Angle	Lens	Intensity		Vf Typ. (V)	Test Current (mA)
					Min. (mcd)	Typ. (mcd)		
<b>Top Mount 0603 Industrial Footprint with 0.6 mm Height (C191)</b>								
<b>1.6 x 0.8 x 0.6 mm (L x W x H)</b>								
HSMH-C191	AS AlGaAs Red	639	170°	Diffused	7.2	17	1.8	20
HSMD-C191	GaP Orange	604	170°	Diffused	2.8	8	2.2	20
HSMG-C191	GaP Green	572	170°	Diffused	4.5	5	2.2	20
HSMS-C191	GaP Red	626	170°	Diffused	2.8	10	2.1	20
HSMY-C191	GaP Yellow	586	170°	Diffused	2.8	8	2.1	20
HSMA-C191	AS AllnGaP Amber	592	170°	Diffused	28.5	90	1.9	20
HSMC-C191	AS AllnGaP Red	626	170°	Diffused	28.5	90	1.9	20
HSML-C191	AS AllnGaP Orange	605	170°	Diffused	28.5	90	1.9	20
HSMN-C191	InGaN Blue	470	170°	Diffused	11.2	35	3.3	20
HSMQ-C191	InGaN Green	527	140°	Diffused	45	145	3.4	20
HSMR-C191	InGaN Blue	473	140°	Diffused	18	55	3.4	20

Quantity: 4,000 per 7 inch reel

<b>Top Mount 0805 Industrial Footprint with 0.4 mm Height (C177)</b>								
<b>2.0 x 1.25 x 0.4 mm (L x W x H)</b>								
HSMD-C177	GaP Orange	604	130°	Diffused	2.8	8	2.2	20
HSMG-C177	GaP Green	572	130°	Diffused	4.5	5	2.2	20
HSMS-C177	GaP Red	626	130°	Diffused	2.8	10	2.1	20
HSMA-C177	AS AllnGaP Amber	592	130°	Diffused	28.5	90	1.9	20
HSMC-C177	AS AllnGaP Red	626	130°	Diffused	28.5	90	1.9	20
HSML-C177	AS AllnGaP Orange	605	130°	Diffused	28.5	90	1.9	20

Quantity: 4,000 per 7 inch reel

<b>Top Mount 0603 Industrial Footprint with 0.4 mm Height (C197)</b>								
<b>1.6 x 0.8 x 0.4 mm (L x W x H)</b>								
HSMD-C197	GaP Orange	604	130°	Diffused	2.8	8	2.2	20
HSMG-C197	GaP Green	572	130°	Diffused	4.5	5	2.2	20
HSMS-C197	GaP Red	626	130°	Diffused	2.8	10	2.1	20
HSMY-C197	GaP Yellow	586	130°	Diffused	2.8	8	2.1	20
HSMA-C197	AS AllnGaP Amber	592	130°	Diffused	28.5	90	1.9	20
HSMC-C197	AS AllnGaP Red	626	130°	Diffused	28.5	90	1.9	20
HSML-C197	AS AllnGaP Orange	605	130°	Diffused	28.5	90	1.9	20

Quantity: 4,000 per 7 inch reel

<b>Top Mount 0402 Industrial Footprint with 0.4 mm Height (C280)</b>								
<b>1.0 x 0.5 x 0.4 mm (L x W x H)</b>								
HSMA-C280	AS AllnGaP Amber	592	130°	Diffused	28.5	90	1.9	20
HSMC-C280	AS AllnGaP Red	626	130°	Diffused	28.5	90	1.9	20
HSMG-C280	GaP Green	572	130°	Diffused	4.5	15	2.2	20
HSMS-C280	GaP Red	626	130°	Diffused	2.8	10	2.1	20
HSMY-C280	GaP Yellow	586	130°	Diffused	2.8	8	2.1	20

Quantity: 4,000 per 7 inch reel

# LED Indicators and Displays

## Surface Mount ChipLEDs

Part Number	Color	Dominant Wavelength (nm)	Viewing Angle	Lens	Intensity		Vf Typ. (V)	Test Current (mA)
					Min. (mcd)	Typ. (mcd)		
<b>Top Mount 0603 Industrial Footprint with 0.35 mm Height (C130)</b>								
<b>1.6 x 0.8 x 0.35 mm (L x W x H)</b>								
HSMA-C130	AllnGaP Amber	592	110°	Diffused	28.5	87	2	20
HSMC-C130	AllnGaP Red	626	110°	Diffused	28.5	131	1.9	20
HSME-C130	AllnGaP Green	572	110°	Diffused	18	54	1.9	20
HSML-C130	AllnGaP Orange	605	110°	Diffused	28.5	139	1.9	20
HSMR-C130	InGaN Blue	473	145°	Diffused	18	55	3.4	20

Quantity: 4,000 per 7 inch reel

<b>Leadframe Top Mount 0603 Industrial Footprint with 0.25 mm Height (CL25)</b>								
<b>1.6 x 0.8 x 0.25 mm (L x W x H)</b>								
HSMR-CL25	InGaN Blue	473	120°	Non-diffused	11.2	18	2.85	5

Quantity: 4,000 per 7 inch reel

<b>Right Angle 1 mm Height (C110)</b>								
<b>3.2 x 1.5 x 1.0 mm (L x W x H)</b>								
HSMH-C110	AS AlGaAs Red	639	130°	Non-diffused	7.2	17	1.8	20
HSMC-C110	GaP Orange	604	130°	Non-diffused	2.8	8	2.2	20
HSMG-C110	GaP Green	572	130°	Non-diffused	4.5	15	2.2	20
HSMS-C110	GaP Red	626	130°	Non-diffused	2.8	10	2.1	20
HSMY-C110	GaP Yellow	586	130°	Non-diffused	2.8	8	2.1	20
HSMA-C110	AS AllnGaP Amber	592	130°	Non-diffused	28.5	95	1.9	20
HSMC-C110	AS AllnGaP Red	626	130°	Non-diffused	28.5	95	1.9	20
HSML-C110	AS AllnGaP Orange	605	130°	Non-diffused	28.5	95	1.9	20
HSMB-C110	GaN Blue	466	130°	Non-diffused	1.8	6.5	3.8	20
HSMZ-C110	TS Red	631	130°	Non-diffused	45	170	2.2	20
HSMH-C110	InGaN Green	525	130°	Non-diffused	45	126	3.3	20
HSMN-C110	InGaN Blue	470	130°	Non-diffused	11.2	39	3.3	20
HSMQ-C110	InGaN Green	527	130°	Non-diffused	45	150	3.4	20
HSMR-C110	InGaN Blue	473	130°	Non-diffused	18	60	3.4	20

Quantity: 3,000 per 7 inch reel

# LED Indicators and Displays

## Surface Mount ChipLEDs

Part Number	Color	Dominant Wavelength (nm)	Viewing Angle	Lens	Intensity		Vf Typ. (V)	Test Current (mA)
					Min. (mcd)	Typ. (mcd)		
<b>Right Angle 0.6 mm Height (C120)</b>								
<b>1.6 x 1.0 x 0.6 mm (L x W x H)</b>								
HSMH-C120	AS AlGaAs	639	155°	Non-diffused	7.2	17	1.8	20
HSMD-C120	GaP Orange	604	155°	Non-diffused	2.8	8	2.2	20
HSMG-C120	GaP Green	572	155°	Non-diffused	4.5	15	2.2	20
HSMA-C120	AS AllnGaP Amber	592	155°	Non-diffused	28.5	90	1.9	20
HSMC-C120	AS AllnGaP Red	626	155°	Non-diffused	28.5	90	1.9	20
HSML-C120	AS AllnGaP Orange	605	155°	Non-diffused	28.5	90	1.9	20
HSMH-C120	InGaN Green	525	155°	Non-diffused	45	120	3.4	20
HSMN-C120	InGaN Blue	470	155°	Non-diffused	11.2	30	3.4	20
HSMQ-C120	InGaN Green	527	155°	Non-diffused	45	145	3.4	20
HSMR-C120	InGaN Blue	473	155°	Non-diffused	18	55	3.4	20

Quantity: 4,000 per 7 inch reel

<b>Right Angle 0.4 mm Height (Cx00)</b>								
<b>1.6 x 1.0 x 0.4 mm (L x W x H)</b>								
ASMT-CA00	AllnGaP Amber	592	150°	Non-diffused	28.5	90	1.9	20
ASMT-CB00	InGaN Blue	473	150°	Non-diffused	7.2	18	2.85	5
ASMT-CW00	InGaN White	Chromaticity Coordinates Bin A1-D2	170°	Diffused	18	35	2.85	5

Quantity: 4,000 per 7 inch reel

<b>Reverse Mount (C265)</b>								
<b>3.4 x 1.25 x 1.1 mm (L x W x H)</b>								
HSMA-C265	AS AllnGaP Amber	592	150°	Non-diffused	28.5	75	1.9	20
HSMC-C265	AS AllnGaP Red	626	150°	Non-diffused	28.5	75	1.9	20
HSME-C265	AS AllnGaP Green	572	170°	Non-diffused	18	50	2.1	20
HSML-C265	AS AllnGaP Orange	605	150°	Non-diffused	28.5	75	1.9	20
HSMG-C265	GaP Green	572	170°	Non-diffused	4.5	15	2.2	20
HSMH-C265	AS AlGaAs Red	639	170°	Non-diffused	7.2	17	1.8	20

Quantity: 3,000 per 7 inch reel

# LED Indicators and Displays

## Surface Mount ChipLEDs

Part Number	Color	Dominant Wavelength (nm)	Viewing Angle	Lens	Intensity		Vf Typ. (V)	Test Current (mA)
					Min. (mcd)	Typ. (mcd)		
<b>Bicolor Top Mount 1210 Industrial Footprint (C15x)</b>								
<b>3.2 x 2.7 x 1.1 mm (L x W x H)</b>								
HSMF-C153	GaP Yellow	586	170°	Diffused	2.8	8	2.1	20
	GaP Red	626	170°	Diffused	2.8	10	2.1	20
HSMF-C155	GaP Green	572	170°	Diffused	4.5	15	2.2	20
	GaP Red	626	170°	Diffused	2.8	10	2.1	20
HSMF-C156	GaP Green	572	170°	Diffused	4.5	15	2.2	20
	GaP Yellow	586	170°	Diffused	2.8	8	2.1	20
HSMF-C157	GaP Green	572	170°	Diffused	4.5	15	2.2	20
	GaP Orange	604	170°	Diffused	2.8	8	2.2	20
HSMF-C158	AllnGaP Green	572	170°	Diffused	28.5	45	2.1	20
	AllnGaP Amber	626	170°	Diffused	28.5	55	1.9	20

Quantity: 3,000 per 7 inch reel

<b>Bicolor Top Mount 0603 Industrial Footprint (C16x)</b>								
<b>1.6 x 0.8 x 0.5 mm (L x W x H)</b>								
HSMF-C162	AllnGaP Amber	592	120°	Diffused	28.5	90	1.9	20
	AllnGaP Red	626	120°	Diffused	28.5	90	1.9	20
HSMF-C163	InGaN Green	525	120°	Diffused	18	45	3.4	10
	AllnGaP Red	626	120°	Diffused	11.2	35	1.8	10
HSMF-C164	InGaN Blue	470	120°	Diffused	2.8	10	3.4	10
	AllnGaP Red	626	120°	Diffused	11.2	35	1.8	10
HSMF-C165	GaP Green	572	120°	Diffused	4.5	15	2.2	20
	GaP Red	626	120°	Diffused	2.8	10	2.1	20
HSMF-C166	GaP Green	572	120°	Diffused	4.5	15	2.2	20
	GaP Yellow	586	120°	Diffused	2.8	8	2.1	20
HSMF-C167	GaP Green	572	120°	Diffused	4.5	15	2.2	20
	GaP Orange	604	120°	Diffused	2.8	8	2.2	20
HSMF-C168	InGaN Blue	470	120°	Diffused	2.8	10	3.4	10
	InGaN Green	525	120°	Diffused	18	45	3.4	10
HSMF-C169	InGaN Blue	470	120°	Diffused	2.8	10	3.4	10
	AllnGaP Amber	592	120°	Diffused	11.2	35	1.8	10

Quantity: 4,000 per 7 inch reel

<b>Tricolor Top Mount 1210 Industrial Footprint (C118)</b>								
<b>3.2 x 2.7 x 1.1 mm (L x W x H)</b>								
HSMF-C118	GaP Green	525	130°	Diffused	45	120	3.5	20
	AllnGaP Red	626	135°	Diffused	28.5	90	1.9	20
	InGaN Blue	470	125°	Diffused	11.2	40	3.5	20

Quantity: 3,000 per 7 inch reel

<b>Tricolor Right Angle with 1.0 mm Height (C11x)</b>								
<b>2.5 x 1.0 x 1.0 mm (L x W x H)</b>								
HSMF-C113	AllnGaP Red	626	120°	Diffused	28.5	80	1.9	20
	AllnGaP Green	572	125°	Diffused	18	50	2	20
	InGaN Blue	470	125°	Diffused	28.5	60	3.4	20
HSMF-C115	AllnGaP Red	626	120°	Diffused	28.5	80	1.9	20
	InGaN Green	525	125°	Diffused	71.5	170	3.4	20
	InGaN Blue	470	125°	Diffused	28.5	60	3.4	20

Quantity: 3,000 per 7 inch reel

# LED Indicators and Displays

## Surface Mount ChipLEDs

Part Number	Color	Dominant Wavelength (nm)	Viewing Angle	Lens	Intensity		Vf Typ. (V)	Test Current (mA)
					Min. (mcd)	Typ. (mcd)		
<b>Tricolor Top Mount with 0.35mm Height (C114)</b>								
<b>1.6 x 1.5 x 0.35 mm (L x W x H)</b>								
HSMF-C114	AllInGaP Red	626	140°	Diffused	28.5	85	1.9	20
	InGaN Green	525	145°	Diffused	45	180	3.4	20
	InGaN Blue	470	145°	Diffused	28.5	70	3.4	20

Quantity: 4,000 per 7 inch reel

<b>Leadframe-based (ASMT-Rx45)</b>								
<b>1.6 x 0.8 x 0.45 mm (L x W x H)</b>								
ASMT-RR45	AllInGaP Red	622	145°	Diffused	50	120	2	20
ASMT-RF45	AllInGaP Yellow Green	573	145°	Diffused	30	60	2	20
ASMT-RA45	AllInGaP Amber	591	145°	Diffused	40	90	2	20

### Standard Intensity Categories

Bin ID	Intensity (mcd)	
	Min.	Max.
A	0.11	0.18
B	0.18	0.29
C	0.29	0.45
D	0.45	0.72
E	0.72	1.10
F	1.10	1.80
G	1.80	2.80
H	2.80	4.50
J	4.50	7.20
K	7.20	11.20
L	11.20	18.00
M	18.00	28.50
N	28.50	45.00
P	45.00	71.50
Q	71.50	112.50
R	112.50	180.00
S	180.00	285.00
T	285.00	450.00
U	450.00	715.00
V	715.00	1125.00
W	1125.00	1800.00
X	1800.00	2850.00
Y	2850.00	4500.00

Tolerance: ±15%

### Color Binnings

Package	Color Bin	Wavelength (nm)	
		Min.	Max.
GaN/InGaN Blue	A	460.0	465.0
	B	465.0	470.0
	C	470.0	475.0
	D	475.0	480.0
InGaN Green	A	515.0	520.0
	B	520.0	525.0
	C	525.0	530.0
	D	530.0	535.0
Orange	A	597.0	600.0
	B	600.0	603.0
	C	603.0	606.0
	D	606.0	609.0
	E	609.0	612.0
	F	612.0	615.0
Red	Full Distribution		
AlGaAs Red	Full Distribution		

Tolerance: ± 1.0 nm

Package	Color Bin	Wavelength (nm)	
		Min.	Max.
Green	A	561.5	564.5
	B	564.5	567.5
	C	567.5	570.5
	D	570.5	573.5
	E	573.5	576.5
Yellow	A	582.0	584.5
	B	584.5	587.0
	C	587.0	589.5
	D	589.5	592.0
	E	592.0	594.5
	F	594.5	597.0
Amber	A	582.0	584.5
	B	584.5	587.0
	C	587.0	589.5
	D	589.5	592.0
	E	592.0	594.5
	F	594.5	597.0

Tolerance: ± 0.5 nm

# LED Indicators and Displays

## Surface Mount ChipLEDs

### Package Dimensions

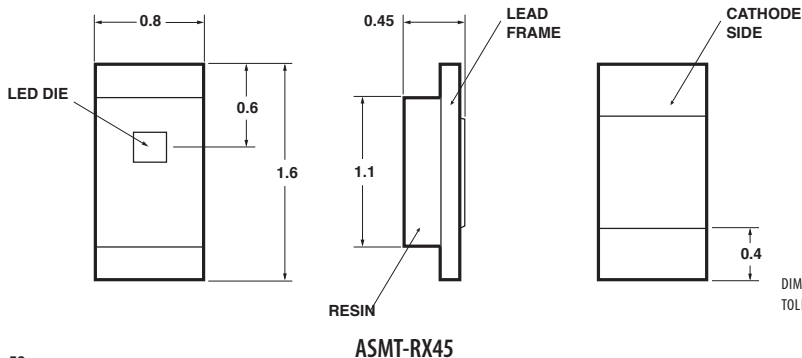
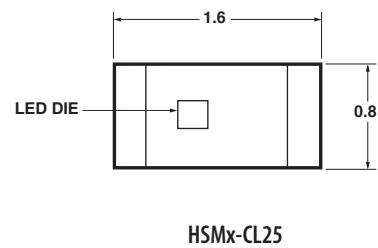
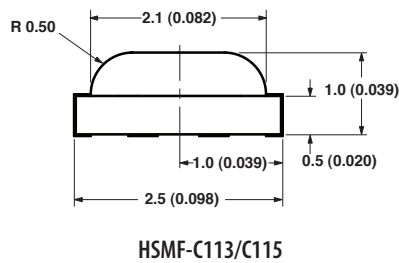
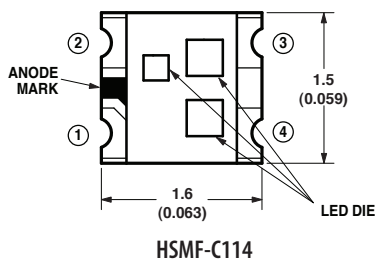
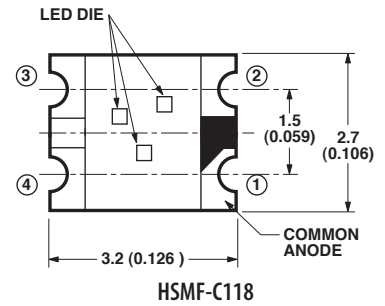
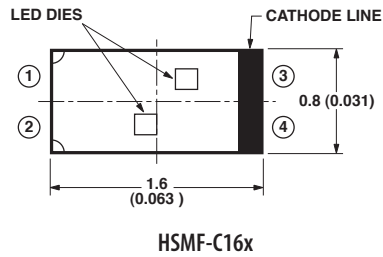
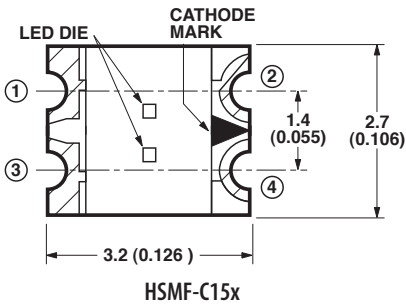
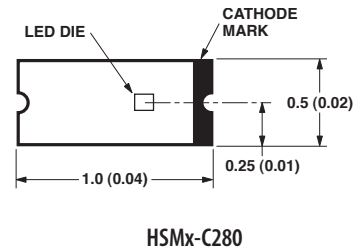
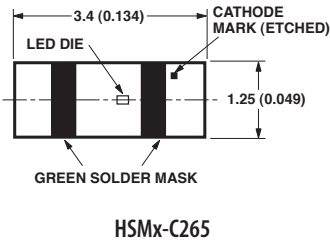
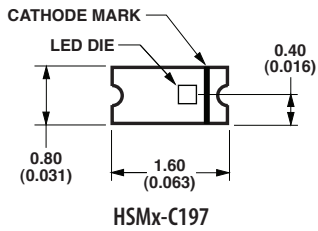
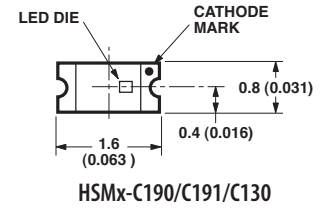
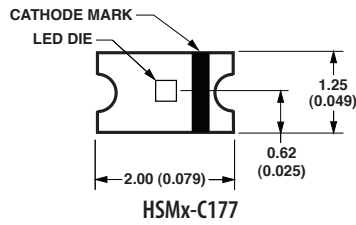
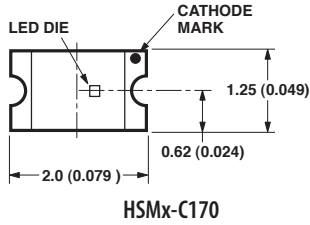
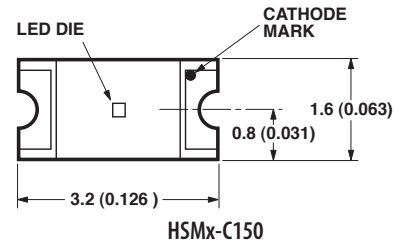
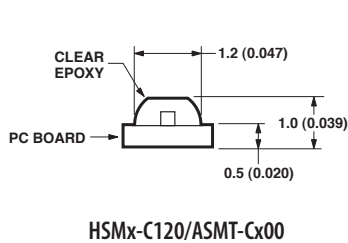
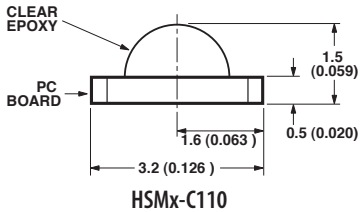

DIMENSIONS ARE IN MILLIMETERS (INCHES).  
TOLERANCE IS  $\pm 0.1$  MM ( $\pm 0.004$  IN.) UNLESS OTHERWISE SPECIFIED.

## Auto Focus Auxiliary Flash LED

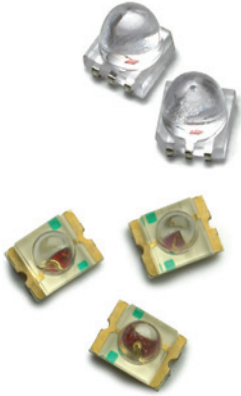

### Description

Avago Technologies offer Auto Focus Auxiliary Flash LEDs in the standard package as well as miniature package. These are surface mount dome lamps that use an untinted, non-diffused lens to provide a high luminous intensity within a narrow radiation pattern.

These narrow angle SMT lamp packages are designed for applications which require long distance illumination and narrow beam pattern such as auxiliary flash for auto-focus function in digital still camera. The miniature package is also suitable for applications that have constraints in design area. These devices are compatible with Pb-free reflow soldering process.

The standard Auto Focus Auxiliary Flash LEDs are available in 530nm Green and 605nm Orange. The miniature package is available in 605nm Orange.

### Eye Safety Classification

These Surface Mount AF Lamps are used for camera applications. The Orange LED is safe to be operated under all driving conditions up to 50mA; however the Green LED is limited by the current. The LEDs have lenses, which focus the beam at about 10mm from the front of the lens, from where the beam diverges relatively slowly. If the Orange LED is placed in a product, it would create a Class 1 LED to IEC/EN 60825-1 (2001) at the recommended input current as long as no collimating optics are added to the optical path. The Green LED is tested as Class 1 to IEC/EN 60825-1 (2001) under operation at 20mA. This LED is not recommended to drive beyond 20mA as part may fall in the classification of Class 2M to IEC/EN 60825-1 (2001).

### Features and Benefits

- Smooth, Consistent Narrow Radiation Pattern
- Viewing angle optimized for auto focus function
- > 3m illumination distance
- Standard package: 8° viewing angle for Orange; 6° viewing angle for Green
- Miniature package: 18° View Angle
- Standard package: Small footprint with 4.8L x 4.8W x 5.33H mm
- Miniature package: 3.2L x 2.4W x 2.4H mm package dimension
- Good Intensity Output
- Compatible with 2x Solder Reflow
- Clear, Non-diffused Epoxy
- Allows easy assembly and PCB space saving.
- Compatible with reflow soldering
- IEC/EN 60825-1 Eye Safety Class 1
- RoHS compliant

### Application

- Digital Still Camera

# LED Indicators and Displays

## Standard Auto Focus Auxiliary Flash LED

Part Number	Color	Dominant Wavelength (nm)	Viewing Angle	Lens	Intensity			Vf Typ. (V)	Test Current (mA)
					Min. (cd)	Typ. (cd)	Max. I <sub>v</sub> (cd)		
ASMT-FJ10-ADH00	AllnGaP Orange	605	8°	Clear	9	22	—	2	20
ASMT-FG10-NFJ00	InGaN Green	530	6°	Clear	18	40	56	3.3	20

## Miniature Auto Focus Auxiliary Flash LED

Part Number	Color	Dominant Wavelength (nm)	Viewing Angle	Lens	Intensity			Vf Typ. (V)	Test Current (mA)
					Min. (mcd)	Typ. (mcd)	Max. I <sub>v</sub> (cd)		
ASMT-FJ30-AB000	AllnGaP Orange	605	18°	Clear	5.5	9	—	2	20

## Iv Bin Category

Orange	Min. (cd)	Max. (cd)
B	5.5	7
C	7	9
D	9	11.5
E	11.5	15

Green	Min. (cd)	Max. (cd)
D	9.0	11.5
E	11.5	15.0
F	15.0	19.5
G	19.5	25.5
H	25.5	33.0
I	33.0	43.0
J	43.0	56.0

Iv Tolerance = ±15%

## Color Bin Category

Orange	Min. (nm)	Max. (nm)
A	600	604
B	604	608
C	608	612
1	597	600
2	600	603
3	603	606
4	606	609
5	609	612
Green	Min. (nm)	Max. (nm)
A	515.0	520.0
B	520.0	525.0
C	525.0	530.0
D	530.0	535.0

Tolerance = ±1nm

## Standard Auto Focus Auxiliary Flash LED Package Dimensions

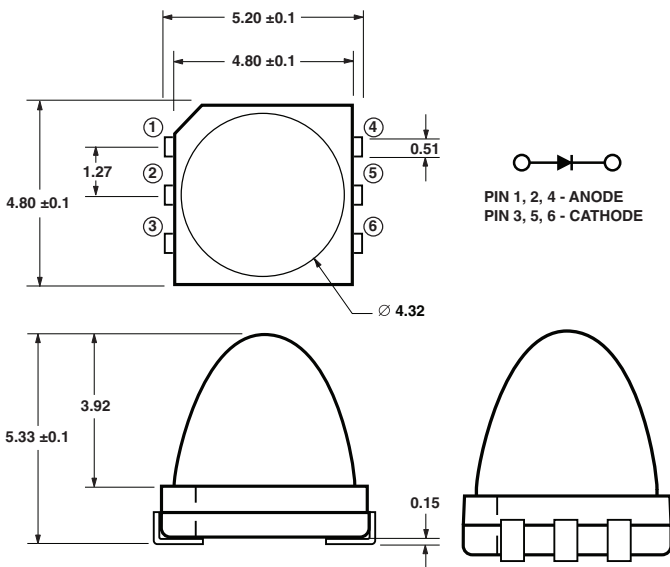

NOTES:  
 1. ALL DIMENSIONS IN MILLIMETERS.  
 2. TOLERANCE IS ±0.1 mm UNLESS OTHERWISE SPECIFIED.

## Miniature Auto Focus Auxiliary Flash LED Package Dimensions

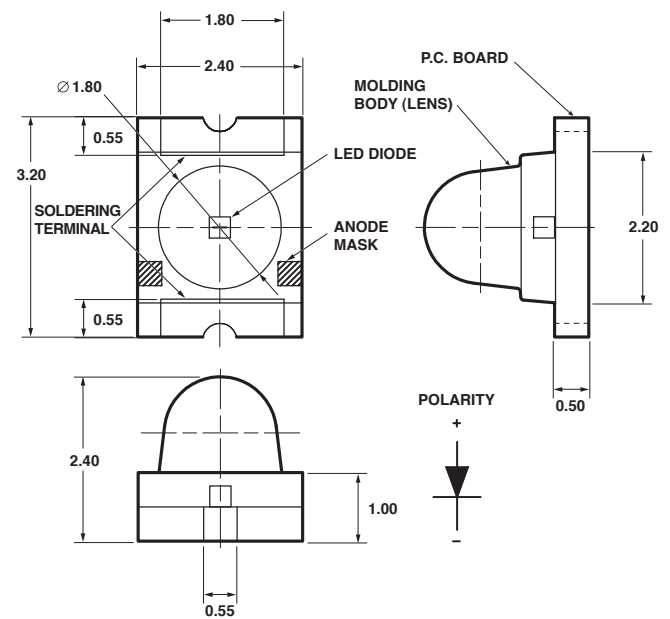

## Flexible Light Strip Module

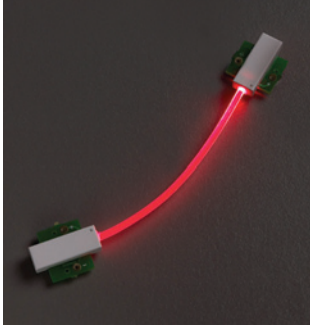

### Description

The Flexible Light Strip Module is a high-performance light tube integrating LEDs solution with excellent thermoplastic polyurethane. This Light Strip is an environmentally friendly “Green Material.” It offers a unique combination of mechanical, physical, and chemical properties, including high-tensile strength, excellent abrasion resistance, outstanding flexibility, weather resistance, non-toxic, recyclable, and decomposable. The Flexible Light Strip Module provides conveniences for the designers to integrate a light strip onto their devices with minimum consideration on optical and mechanical optimization. The specially designed housing helps to concentrate the light for maximum efficiency and the specially designed PCB provides a plug-and-play type of solution for assembly. The total solution provides the ease of design and assembly for designers.

### Features and Benefits

- Outstanding abrasion resistance
- Excellent mechanical properties
- Excellent chemical resistance
- Excellent light transitivity
- High shaping flexibility
- Available length: 100 mm to 500 mm with 1 mm interval
- Available voltage source : 5 V, 9 V and 12 V
- Available colors: Blue, Green, Red and White

### Typical Applications

- Handheld devices
- Cellular phones
- Decorative lighting
- Electronics and electrical appliances

# LED Indicators and Displays

## Flexible Light Strip Module Selection Guide

Part Number	Color	Available Vcc	Housing	Length	Diameter
ASMT-LR50	Red	5, 9, 12 V	Single	226 mm	1.4 mm
ASMT-LG50	Green	5, 9, 12 V	Single	226 mm	1.4 mm
ASMT-LB50	Blue	5, 9, 12 V	Single	226 mm	1.4 mm
ASMT-LW50	White	5, 9, 12 V	Single	226 mm	1.4 mm
ASMT-LR60	Red	5, 9, 12 V	Double	200 mm	1.4 mm
ASMT-LG60	Green	5, 9, 12 V	Double	200 mm	1.4 mm
ASMT-LB60	Blue	5, 9, 12 V	Double	200 mm	1.4 mm
ASMT-LW60	White	5, 9, 12 V	Double	200 mm	1.4 mm

**Notes:**

1. Length option available from 100 mm to 500 mm with the interval of 1 mm
2. Diameter option available 1 mm and 1.4 mm

### Optical Characteristics at $T_A = 25^\circ\text{C}$

Part Number	Luminous Intensity, $I_v^{[1][2]}$ (mcd) @ 20mA		Peak Wavelength, $\lambda_{\text{peak}}^{[1]}$ (nm)	Dominant Wavelength $\lambda_d^{[1][3]}$ (nm)		Luminous Incidence $E_v^{[5]}$ (lm/m <sup>2</sup> )
	Min.	Max.	Typ.	Min.	Max.	Typ.
ASMT-LB50/60	71.5	180.0	468	465	475	30.0
ASMT-LG50/60	180.0	450.0	520.0	515.0	535.0	130.0
ASMT-LR50/60	112.5	285.0	637.0	615.0	630.0	30.0

Part Number	Luminous Intensity, $I_v^{[1][2]}$ (mcd) @ 20mA		Typical Chromaticity Coordinates <sup>[1][4]</sup>		Luminous Incidence $E_v^{[5]}$ (lm/m <sup>2</sup> )
	Min.	Max.	X	Y	Typ.
ASMT-LW50/60	1000	1600	0.31	0.31	230.0

**Notes:**

1. For individual LED light source only.
2. The luminous intensity  $I_v$  is measured at the peak of the spatial radiation pattern which may not be aligned with the mechanical axis of the LED package. Refer to  $I_v$  bin table for binning structure and tolerance.
3. The dominant wavelength,  $\lambda_d$ , is derived from the CIE 1931 Chromaticity Diagram and represents the perceived color of the device. Refer to color bin limit tables for binning structure and tolerance.
4. The chromaticity coordinates are derived from the CIE 1931 Chromaticity Diagram and represent the perceived color of the device. Refer to color bin limit tables for binning structure and tolerance.
5. Measurement done at the center of the elastomer light stripe away from the LED light sources.

### Package Dimensions

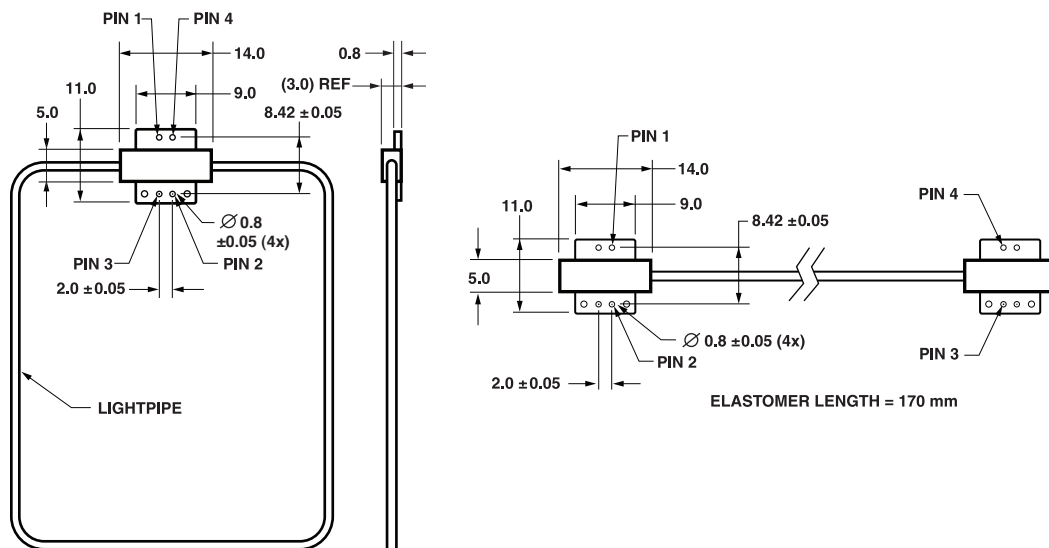

## Seven-Segment Displays

### Description

Avago Technologies offers a full range of seven-segment displays from low cost, standard brightness displays to high ambient light displays that produce up to 7.5 mcd per segment. Dual and single digit displays are available in assorted character heights and colors. They are divided into two platforms to address different market requirements in both industrial and consumer markets. Displays for industrial markets are designed for high-reliability applications and feature extremely durable packaging for high temperature environments. Consumer applications are designed for cost-sensitive, general-purpose display applications.

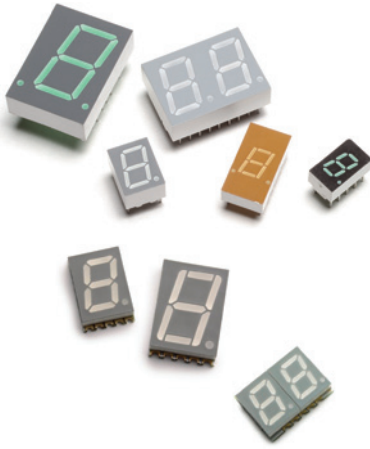

### Product Features and Benefits

- Semiconductor (LED) light source
- Cost-effective solutions
- Flexibility for designers
- Light weight
- Lower power consumption
- Electrical power savings
- Low heat generation
- Low current devices available
- Mechanically rugged
- No wire filaments
- No moving parts
- Not sensitive to mechanical shock and vibration
- Essentially monochromatic light
- No color filter required
- Maximum use of visible light
- Easy for the eye to discern against distracting backgrounds in sunlight and adverse weather conditions
- High light output
- Industry standard size and pinout
- Categorized for luminous intensity (yellow and green categorized for color)

### Industrial Applications: High Performance Seven-segment Display Package

Industrial grade products provide high peak current, automated IV/color binning and the availability of intensity and color selection. Ideal for high reliability applications such as temperature controllers, this package is extremely durable in high temperature environments with better heat dissipation through a mild steel leadframe.

### Key benefits for the leadframe platform

- Heat dissipation from the package is faster than other PCB display products
- Brightness (Iv) degradation reduced over time
- Lead stability and consistency
- Solder coated leads result in better solderability
- Typical epoxy Tg is 140°C resulting in improved temperature cycling reliability

### Consumer Applications: Standard Seven-segment Display Package

Designed for the cost-competitive general purpose commercial LED display applications, this package is built with a PCB substrate using ultrasonic stitch-to-stitch bonding with aluminum wire.

### Key benefits for the PCB platform

- Competitive prices
- Avago Technologies quality, reliability and technical support
- Typical epoxy Tg is 100–120°C, suitable for applications that do not experience extreme temperatures and temperature cycling

Avago Technologies is committed to support the market by offering display performance and features that are specific to the designer's application requirements.

### Typical Industrial Applications

High Performance Seven-segment Displays:

- Temperature controllers
- Test and measurement instrumentation
- Power converters
- Home appliance displays
- Automotive and avionic instrumentation
- Fuel pump displays
- Digital panel meters









### Typical Consumer Applications

Standard Seven-segment Displays:

- Cable set-top boxes
- Electronics displays
- Gaming machines
- Point of sale terminals
- Answering machines
- Exercise equipment





# LED Indicators and Displays







## Through-hole Seven-Segment Displays—Leadframe Platform

Part Number	Face Color	Pin Configuration	Intensity ( $\mu\text{cd}$ )		Iv Test Current (mA)	Vf Typ. (V)	Vf Test Current (mA)	2 Intensity Bin Selection
			Min.	Typ.				
<b>7.6 mm (0.3") Micro Bright Displays (right decimal point)</b>								
<b>GaP Red 626 nm</b> 								
HDSP-7501	Grey	Common Anode	360	980	5	2	20	C,D
HDSP-A211	Black	Common Anode	360	980	5	2	20	
HDSP-7503	Grey	Common Cathode	360	980	5	2	20	C,D
HDSP-A213	Black	Common Cathode	360	980	5	2	20	C,D
<b>GaP Orange 600 nm</b> 								
HDSP-A401	Grey	Common Anode	354	720	5	2	20	
HDSP-A411	Black	Common Anode	354	720	5	2	20	
HDSP-A403	Grey	Common Cathode	354	720	5	2	20	
HDSP-A413	Black	Common Cathode	354	720	5	2	20	
<b>GaP Yellow 586 nm</b> 								
HDSP-7401	Grey	Common Anode	225	480	5	2.2	20	D,E
HDSP-7403	Grey	Common Cathode	225	480	5	2.2	20	D,E
<b>High Performance Green 571 nm</b> 								
HDSP-7801	Grey	Common Anode	860	3000	10	2.1	10	J,K
HDSP-A511	Black	Common Anode	860	3000	10	2.1	10	J,K
HDSP-7803	Grey	Common Cathode	860	3000	10	2.1	10	
HDSP-A513	Black	Common Cathode	860	3000	10	2.1	10	
<b>GaP AlGaAs Red 637 nm</b> 								
HDSP-A151	Grey	Common Anode	690	1400	20	1.8	20	
HDSP-A153	Grey	Common Cathode	690	1400	20	1.8	20	
<b>7.6 mm (0.3") Micro Bright Low Current Displays (right decimal point)</b>								
<b>GaP AlGaAs Red 637 nm</b> 								
HDSP-A101	Grey	Common Anode	315	600	1	1.6	1	F,G
HDSP-A111	Black	Common Anode	315	600	1	1.6	1	F,G
HDSP-A103	Grey	Common Cathode	315	600	1	1.6	1	F,G
HDSP-A113	Black	Common Cathode	315	600	1	1.6	1	
<b>GaP Red 626 nm</b> 								
HDSP-7511	Grey	Common Anode	160	270	2	1.6	2	C,D
HDSP-7513	Grey	Common Cathode	160	270	2	1.6	2	C,D
<b>GaP Yellow 585 nm</b> 								
HDSP-A801	Grey	Common Anode	250	420	4	1.7	4	
HDSP-A803	Grey	Common Cathode	250	420	4	1.7	4	
<b>GaP Green 571 nm</b> 								
HDSP-A901	Grey	Common Anode	250	475	4	1.9	4	
HDSP-A903	Grey	Common Cathode	250	475	4	1.9	4	

# LED Indicators and Displays





## Through-hole Seven-Segment Displays—Leadframe Platform

Part Number	Face Color	Pin Configuration	Intensity ( $\mu\text{cd}$ )		Iv Test Current (mA)	Vf Typ. (V)	Vf Test Current (mA)
			Min.	Typ.			
<b>7.6 mm (0.3") Micro Bright Overflow Displays (right decimal point)</b>							
<b>GaP Red 626 nm</b> 							
HDSP-7507	Grey	Common Anode	360	980	5	2	20
HDSP-7508	Grey	Common Cathode	360	980	5	2	20
<b>GaP Orange 600 nm</b> 							
HDSP-A407	Grey	Common Anode	354	720	5	2	20
HDSP-A408	Grey	Common Cathode	354	720	5	2	20
<b>GaP Yellow 586 nm</b> 							
HDSP-7407	Grey	Common Anode	225	480	5	2.2	20
HDSP-7408	Grey	Common Cathode	225	480	5	2.2	20
<b>GaP Green 571 nm</b> 							
HDSP-7807	Grey	Common Anode	860	3000	10	2.1	10
HDSP-7808	Grey	Common Cathode	860	3000	10	2.1	10

Part Number	Face Color	Pin Configuration	Intensity		Iv Test Current (mA)	Vf Typ. (V)	Vf Test Current (mA)	2 Intensity Bin Selection	Decimal Point
			Min.	Typ.					
<b>7.6 mm (0.3") Single Digit Displays</b>									
<b>GaP Red 626 nm</b> 									
5082-7610	Red	Common Anode	340	800	5	2.1	20	C,D	Left
5082-7611	Red	Common Anode	340	800	5	2.1	20		Right
5082-7613	Red	Common Cathode	340	800	5	2.1	20	C,D	Right
<b>GaP Yellow 586 nm</b> 									
5082-7620	Yellow	Common Anode	205	620	5	2.2	20		Left
5082-7621	Yellow	Common Anode	205	620	5	2.2	20		Right
5082-7623	Yellow	Common Cathode	205	620	5	2.2	20		Right
<b>GaP Green 571 nm</b> 									
HDSP-3600	Green	Common Anode	860	2700	10	2.1	10	K,L	Left
HDSP-3601	Green	Common Anode	860	2700	10	2.1	10		Right
HDSP-3603	Green	Common Cathode	860	2700	10	2.1	10		Right
<b>7.6 mm (0.3") Single Digit Overflow</b>									
<b>GaP Red 626 nm</b> 									
5082-7616	Red	—	340	800	5	2.1	20		Right
<b>GaP Yellow 586 nm</b> 									
5082-7626	Yellow	—	205	620	5	2.2	20		Right
<b>GaP Green 571 nm</b> 									
HDSP-3606	Green	—	860	2700	10	2.1	10		Right









# LED Indicators and Displays

## Through-hole Seven-Segment Displays—Leadframe Platform

Part Number	Face Color	Pin Configuration	Intensity ( $\mu\text{cd}$ )		Iv Test Current (mA)	Vf Typ. (V)	Vf Test Current (mA)	2 Intensity Bin Selection
			Min.	Typ.				
<b>8 mm (0.31") Micro Bright Displays (right decimal point)</b>								
<b>AlGaAs Red 637 nm</b> 								
HDSP-U101	Grey	Common Anode	315	600	1	1.8	20	
HDSP-U111	Black	Common Anode	315	600	1	1.8	20	
HDSP-U103	Grey	Common Cathode	315	600	1	1.8	20	
HDSP-U113	Black	Common Cathode	315	600	1	1.8	20	F,G
<b>GaP Red 626 nm</b> 								
HDSP-U201	Grey	Common Anode	360	980	5	2	20	
HDSP-U211	Black	Common Anode	360	980	5	2	20	C,D
HDSP-U203	Grey	Common Cathode	360	980	5	2	20	C,D
HDSP-U213	Black	Common Cathode	360	980	5	2	20	C,D
<b>GaP Orange 600 nm</b> 								
HDSP-U401	Grey	Common Anode	360	980	5	2	20	
HDSP-U411	Black	Common Anode	360	980	5	2	20	
HDSP-U403	Grey	Common Cathode	360	980	5	2	20	
HDSP-U413	Black	Common Cathode	360	980	5	2	20	
<b>GaP Yellow 586 nm</b> 								
HDSP-U301	Grey	Common Anode	225	480	5	2.2	20	
HDSP-U311	Black	Common Anode	225	480	5	2.2	20	
HDSP-U303	Grey	Common Cathode	225	480	5	2.2	20	
HDSP-U313	Black	Common Cathode	225	480	5	2.2	20	
<b>GaP Green 571 nm</b> 								
HDSP-U501	Grey	Common Anode	860	3000	10	2.1	10	
HDSP-U511	Black	Common Anode	860	3000	10	2.1	10	K,L
HDSP-U503	Grey	Common Cathode	860	3000	10	2.1	10	K,L
HDSP-U513	Black	Common Cathode	860	3000	10	2.1	10	K,L





# LED Indicators and Displays





## Through-hole Seven-Segment Displays—Leadframe Platform

Part Number	Face Color	Pin Configuration	Intensity ( $\mu\text{cd}$ )		Iv Test Current (mA)	Vf Typ. (V)	Vf Test Current (mA)	2 Intensity Bin Selection
			Min.	Typ.				
<b>10 mm (0.4") Single Digit Displays (right decimal point)</b>								
<b>AlGaAs Red 637 nm</b> 								
HDSP-F111	Black	Common Anode	330	650	1	1.6	1	
HDSP-F101	Grey	Common Anode	330	650	1	1.6	1	E,F
HDSP-F113	Black	Common Cathode	330	650	1	1.6	1	
HDSP-F103	Grey	Common Cathode	330	650	1	1.8	1	E,F
<b>GaP Red 626 nm</b> 								
HDSP-F211	Black	Common Anode	420	1200	5	2	20	D,E
HDSP-F201	Grey	Common Anode	420	1200	5	2	20	D,E
HDSP-F213	Black	Common Cathode	420	1200	5	2	20	D,E
HDSP-F203	Grey	Common Cathode	420	1200	5	2	20	D,E
<b>GaP Orange 603 nm</b> 								
HDSP-F411	Black	Common Anode	420	1200	5	2	20	
HDSP-F401	Grey	Common Anode	420	1200	5	2	20	
HDSP-F413	Black	Common Cathode	420	1200	5	2	20	
HDSP-F403	Grey	Common Cathode	420	1200	5	2	20	
<b>GaP Yellow 586 nm</b> 								
HDSP-F301	Grey	Common Anode	290	800	5	2.2	20	D,E
HDSP-F303	Grey	Common Cathode	290	800	5	2.2	20	D,E
<b>GaP Green 571 nm</b> 								
HDSP-F511	Black	Common Anode	1030	3500	10	2.1	10	I,J
HDSP-F501	Grey	Common Anode	1030	3500	10	2.1	10	J,K
HDSP-F513	Black	Common Cathode	1030	3500	10	2.1	10	I,J
HDSP-F503	Grey	Common Cathode	1030	3500	10	2.1	10	J,K
<b>10 mm (0.4") Overflow Displays (right decimal point)</b>								
<b>AlGaAs Red 637 nm</b> 								
HDSP-F107	Grey	Common Anode	330	650	1	1.6	1	
HDSP-F108	Grey	Common Cathode	330	650	1	1.6	1	
<b>GaP Red 626 nm</b> 								
HDSP-F207	Grey	Common Anode	420	1200	5	2	20	
HDSP-F208	Grey	Common Cathode	420	1200	5	2	20	
<b>GaP Orange 603 nm</b> 								
HDSP-F407	Grey	Common Anode	420	1200	5	2	20	
HDSP-F408	Grey	Common Cathode	420	1200	5	2	20	
<b>GaP Yellow 586 nm</b> 								
HDSP-F307	Grey	Common Anode	290	800	5	2.2	20	
HDSP-F308	Grey	Common Cathode	290	800	5	2.2	20	
<b>GaP Green 571 nm</b> 								
HDSP-F507	Grey	Common Anode	1030	3500	10	2.1	10	
HDSP-F508	Grey	Common Cathode	1030	3500	10	2.1	10	

# LED Indicators and Displays





## Through-hole Seven-Segment Displays—Leadframe Platform

Part Number	Face Color	Pin Configuration	Intensity		Iv Test Current (mA)	Vf Typ. (V)	Vf Test Current (mA)	Decimal Point
			Min.	Typ.				
<b>10 mm (0.4") Slim Font Single Digit Displays</b>								
<b>AlGaAs Red 637 nm</b> 								
HDSP-315H	Grey	Common Anode	180	650	1	1.8	1	Right
HDSP-316H	Grey	Common Cathode	180	650	1	1.8	1	Right
<b>GaP Red 626 nm</b> 								
HDSP-315E	Grey	Common Anode	450	2600	10	1.9	10	Right
HDSP-316E	Grey	Common Cathode	450	2600	10	1.9	10	Right
<b>GaP Red 626 nm — Low Current</b> 								
HDSP-315L	Grey	Common Anode	180	370	2	2.1	2	Right
HDSP-316L	Grey	Common Cathode	180	370	2	2.1	2	Right
<b>GaP Yellow 586 nm</b> 								
HDSP-315Y	Grey	Common Anode	450	1800	10	2	10	Right
HDSP-316Y	Grey	Common Cathode	450	1800	10	2	10	Right
<b>GaP Green 571 nm</b> 								
HDSP-315G	Grey	Common Anode	450	5000	10	2.1	10	Right
HDSP-316G	Grey	Common Cathode	450	5000	10	2.1	10	Right

Part Number	Face Color	Pin Configuration	Intensity		Iv Test Current (mA)	Vf Typ. (V)	Vf Test Current (mA)	2 Intensity Bin Selection	Decimal Point
			Min.	Typ.					
<b>10 mm (0.4") Slim Font Single Digit Displays</b>									
<b>AlGaAs Red 637 nm</b> 									
HDSP-E106	Grey	—	390	650	1	1.6	1		Right
<b>GaP Red 626 nm</b> 									
HDSP-E106	Grey	—	390	650	1	1.6	1		Right
<b>GaP Red 626 nm — Low Current</b> 									
5082-7656	Red	—	340	1115	5	2.1	20		Right
<b>GaP Yellow 586 nm</b> 									
5082-7666	Yellow	—	290	835	5	2.2	20		Right
<b>GaP Green 571 nm</b> 									
HDSP-4606	Grey	—	1030	4000	10	2.1	10	I,J	Right

# LED Indicators and Displays

## Through-hole Seven-Segment Displays—Leadframe Platform

Part Number	Face Color	Pin Configuration	Intensity ( $\mu\text{cd}$ )		I <sub>v</sub> Test Current (mA)	V <sub>f</sub> Typ. (V)	V <sub>f</sub> Test Current (mA)
			Min.	Typ.			
<b>10 mm (0.4") Dual Digit Displays (right decimal point)</b>							
<b>AlGaAs Red 637 nm</b> 							
HDSP-G111	Black	Common Anode	330	650	1	1.6	1
HDSP-G101	Grey	Common Anode	330	650	1	1.6	1
HDSP-G113	Black	Common Cathode	330	650	1	1.6	1
HDSP-G103	Grey	Common Cathode	330	650	1	1.6	1
<b>GaP Red 626 nm</b> 							
HDSP-G211	Black	Common Anode	420	1200	5	2	2
HDSP-G201	Grey	Common Anode	420	1200	5	2	20
HDSP-G213	Black	Common Cathode	420	1200	5	2	20
HDSP-G203	Grey	Common Cathode	420	1200	5	2	20
<b>GaP Orange 603 nm</b> 							
HDSP-G411	Black	Common Anode	420	1200	5	2	20
HDSP-G401	Grey	Common Anode	420	1200	5	2	20
HDSP-G413	Black	Common Cathode	420	1200	5	2	20
HDSP-G403	Grey	Common Cathode	420	1200	5	2	20
<b>GaP Yellow 586 nm</b> 							
HDSP-G301	Grey	Common Anode	290	800	5	2.2	20
HDSP-G303	Grey	Common Cathode	290	800	5	2.2	20
<b>GaP Green 571 nm</b> 							
HDSP-G511	Black	Common Anode	1030	3500	10	2.1	10
HDSP-G501	Grey	Common Anode	1030	3500	10	2.1	10
HDSP-G513	Black	Common Cathode	1030	3500	10	2.1	10
HDSP-G503	Grey	Common Cathode	1030	3500	10	2.1	10





# LED Indicators and Displays

## Through-hole Seven-Segment Displays—Leadframe Platform

Part Number	Face Color	Pin Configuration	Intensity		I <sub>v</sub> Test Current (mA)	V <sub>f</sub> Typ. (V)	V <sub>f</sub> Test Current (mA)	2 Intensity Bin Selection	Decimal Point
			Min.	Typ.					
<b>10.9 mm (0.43") Single Digit Displays</b>									
<b>AlGaAs Red 637 nm</b> <span style="color: red;">■</span>									
HDSP-E101	Grey	Common Anode	390	650	1	1.6	1	E,F	Right
HDSP-E103	Grey	Common Cathode	390	650	1	1.6	1		Right
<b>GaP Red 626 nm</b> <span style="color: red;">■</span>									
5082-7650	Red	Common Anode	340	1115	5	2.1	20	D,E	Left
5082-7651	Red	Common Anode	340	1115	5	2.1	20	D,E	Right
5082-7653	Red	Common Cathode	340	1115	5	2.1	20	D,E	Right
<b>GaP Red 626 nm — Low Current</b> <span style="color: orange;">■</span>									
HDSP-3350	Red	Common Anode	200	300	2	1.6	2		Left
HDSP-3351	Red	Common Anode	200	300	2	1.6	2		Right
HDSP-3353	Red	Common Cathode	200	300	2	1.6	2		Right
<b>GaP Yellow 586 nm</b> <span style="color: yellow;">■</span>									
5082-7660	Yellow	Common Anode	290	835	5	2.2	20		Left
5082-7661	Yellow	Common Anode	290	835	5	2.2	20		Right
5082-7663	Yellow	Common Cathode	290	835	5	2.2	20		Right
<b>GaP Green 571 nm</b> <span style="color: green;">■</span>									
HDSP-4600	Grey	Common Anode	1030	4000	10	2.1	10		Left
HDSP-4601	Grey	Common Anode	1030	4000	10	2.1	10		Right
HDSP-4603	Grey	Common Cathode	1030	4000	10	2.1	10	I,J	Right

# LED Indicators and Displays

## Through-hole Seven-Segment Displays—Leadframe Platform

Part Number	Face Color	Pin Configuration	Intensity		I <sub>v</sub> Test Current (mA)	V <sub>f</sub> Typ. (V)	V <sub>f</sub> Test Current (mA)	2 Intensity Bin Selection	Decimal Point
			Min.	Typ.					
<b>13 mm (0.56") Slim Font Displays</b>									
<b>AlGaAs Red 637 nm</b> 									
HDSP-515H	Grey	Common Anode	180	650	1	1.8	1	G,H	Right
HDSP-516H	Grey	Common Cathode	180	650	1	1.8	1		Right
<b>GaP Red 626 nm</b> 									
HDSP-515E	Grey	Common Anode	450	2600	10	1.9	10		Right
HDSP-516E	Grey	Common Cathode	450	2600	10	1.9	10		Right
<b>GaP Red 626 nm — Low Current</b> 									
HDSP-515L	Grey	Common Anode	180	370	2	2.1	2	F,G	Right
HDSP-516L	Grey	Common Cathode	180	370	2	2.1	2		Right
<b>GaP Yellow 586 nm</b> 									
HDSP-515Y	Grey	Common Anode	450	1800	10	2	10		Right
HDSP-516Y	Grey	Common Cathode	450	1800	10	2	10		Right
<b>GaP Green 571 nm</b> 									
HDSP-515G	Grey	Common Anode	450	5000	10	2.1	10		Right
HDSP-516G	Grey	Common Cathode	450	5000	10	2.1	10		Right







# LED Indicators and Displays

## Through-hole Seven-Segment Displays—Leadframe Platform

Part Number	Face Color	Pin Configuration	Intensity ( $\mu\text{cd}$ )		Iv Test Current (mA)	Vf Typ. (V)	Vf Test Current (mA)	2 Intensity Bin Selection
			Min.	Typ.				
<b>14.2 mm (0.56") Single Digit Displays (right decimal point)</b>								
<b>AlGaAs Red 637 nm</b> <span style="color: red;">■</span>								
HDSP-H111	Black	Common Anode	400	700	1	1.6	1	D,E
HDSP-H101	Grey	Common Anode	400	700	1	1.6	1	D,E
HDSP-H113	Black	Common Cathode	400	700	1	1.6	1	
HDSP-H103	Grey	Common Cathode	400	700	1	1.6	1	D,E
<b>GaP Red 626 nm</b> <span style="color: red;">■</span>								
HDSP-H211	Black	Common Anode	900	2800	10	2	20	G,H
HDSP-5501	Grey	Common Anode	900	2800	10	2.1	20	G,H
HDSP-H213	Black	Common Cathode	900	2800	10	2	20	G,H
HDSP-5503	Grey	Common Cathode	900	2800	10	2.1	20	G,H
<b>GaP Red 626 nm — Low Current</b> <span style="color: red;">■</span>								
HDSP-5551	Grey	Common Anode	270	370	2	1.6	2	
HDSP-5553	Grey	Common Cathode	270	370	2	1.6	2	B,C
<b>GaP Orange 600 nm</b> <span style="color: orange;">■</span>								
HDSP-H411	Black	Common Anode	1190	2000	10	2	20	
HDSP-H401	Grey	Common Anode	1190	2000	10	2	20	
HDSP-H413	Black	Common Cathode	1190	2000	10	2	20	
HDSP-H403	Grey	Common Cathode	1190	2000	10	2	20	
<b>GaP Yellow 586 nm</b> <span style="color: yellow;">■</span>								
HDSP-5701	Grey	Common Anode	600	1800	10	2.1	20	F,G
HDSP-5703	Grey	Common Cathode	600	1800	10	2.1	20	F,G
<b>GaP Green 571 nm</b> <span style="color: green;">■</span>								
HDSP-H511	Black	Common Anode	900	2500	10	2.1	10	G,H
HDSP-5601	Grey	Common Anode	900	2500	10	2.1	10	G,H
HDSP-H513	Black	Common Cathode	900	2500	10	2.1	10	G,H
HDSP-5603	Grey	Common Cathode	900	2500	10	2.1	10	G,H

# LED Indicators and Displays

## Through-hole Seven-Segment Displays—Leadframe Platform

Part Number	Face Color	Pin Configuration	Intensity ( $\mu\text{cd}$ )		Iv Test Current (mA)	Vf Typ. (V)	Vf Test Current (mA)	2 Intensity Bin Selection
			Min.	Typ.				
<b>14.2 mm (0.56") Overflow Displays (right decimal point)</b>								
<b>AlGaAs Red 637 nm</b> 								
HDSP-H107	Grey	Common Anode	400	700	1	1.6	1	
HDSP-H108	Grey	Common Cathode	400	700	1	1.6	1	
<b>GaP Red 626 nm</b> 								
HDSP-5507	Grey	Common Anode	900	2800	10	2.1	20	G,H
HDSP-5508	Grey	Common Cathode	900	2800	10	2.1	20	G,H
<b>GaP Red 626 nm — Low Current</b> 								
HDSP-5557	Grey	Common Anode	270	370	2	1.6	2	
HDSP-5558	Grey	Common Cathode	270	370	2	1.6	2	
<b>GaP Orange 600 nm</b> 								
HDSP-H407	Grey	Common Anode	1190	2000	10	2	20	
HDSP-H408	Grey	Common Cathode	1190	2000	10	2	20	
<b>GaP Yellow 586 nm</b> 								
HDSP-5707	Grey	Common Anode	600	1800	10	2.1	20	
HDSP-5708	Grey	Common Cathode	600	1800	10	2.1	20	
<b>GaP Green 571 nm</b> 								
HDSP-5607	Grey	Common Anode	900	2500	10	2.1	10	
HDSP-5608	Grey	Common Cathode	900	2500	10	2.1	10	





# LED Indicators and Displays

## Through-hole Seven-Segment Displays—Leadframe Platform

Part Number	Face Color	Pin Configuration	Intensity		I <sub>v</sub> Test Current (mA)	V <sub>f</sub> Typ. (V)	V <sub>f</sub> Test Current (mA)	2 Intensity Bin Selection	Decimal Point
			Min.	Typ.					
<b>20 mm (0.8") Single Digit Displays</b>									
<b>AlGaAs Red 637 nm</b> <span style="color: red;">■</span>									
HDSP-N100	Grey	Common Anode	270	590	1	1.6	1		Left
HDSP-N101	Grey	Common Anode	270	590	1	1.6	1		Right
HDSP-N103	Grey	Common Cathode	270	590	1	1.6	1		Right
HDSP-N105	Grey	Common Cathode	270	590	1	1.6	1		Left
<b>GaP Red 626 nm</b> <span style="color: red;">■</span>									
HDSP-3901	Grey	Common Anode	3350	7000 Peak (1/5 df)		2.6	100	E,F	Right
HDSP-3903	Grey	Common Cathode	3350	7000		2.6	100	E,F	Right
HDSP-3905	Grey	Common Cathode	3350	7000		2.6	100		Left
<b>GaP Orange 600 nm</b> <span style="color: orange;">■</span>									
HDSP-N401	Grey	Common Anode	2230	– Peak (1/5 df)	100 mA	2.6	100		Right
HDSP-N403	Grey	Common Cathode	2230	–		2.6	100		Right
<b>GaP Yellow 586 nm</b> <span style="color: yellow;">■</span>									
HDSP-4200	Grey	Common Left Hand	2200	7000 Peak (1/5 df)	100 mA	2.6	100		Left
HDSP-4201	Grey	Common Anode	2200	7000		2.6	100		Right
HDSP-4203	Grey	Common Cathode	2200	7000		2.6	100		Right
HDSP-4205	Grey	Common Cathode	2200	7000		2.6	100		Left
<b>GaP Green 571 nm</b> <span style="color: green;">■</span>									
HDSP-8600	Grey	Common Anode	680	1500	10	2.1	10		Left
HDSP-8601	Grey	Common Anode	680	1500	10	2.1	10	E,F	Right
HDSP-8603	Grey	Common Cathode	680	1500	10	2.1	10	E,F	Right
HDSP-8605	Grey	Common Cathode	680	1500	10	2.1	10		Left









# LED Indicators and Displays

## Through-hole Seven-Segment Displays—Leadframe Platform

Part Number	Face Color	Pin Configuration	Intensity		I <sub>v</sub> Test Current (mA)	V <sub>f</sub> Typ. (V)	V <sub>f</sub> Test Current (mA)	Decimal Point
			Min.	Typ.				
<b>20 mm (0.8") Single Digit Overflow Displays</b>								
<b>AlGaAs Red 637 nm</b> 								
HDSP-N106	Grey	–	270	590	1	1.6	1	Left
<b>GaP Red 626 nm</b> 								
HDSP-3906	Grey	–	3350	7000 Peak (1/5 df)	100 mA	2.6	100	Right
<b>GaP Orange 600 nm</b> 								
HDSP-N406	Grey	–	2230	7000 Peak (1/5 df)	100 mA	2.6	100	Right
<b>GaP Yellow 586 nm</b> 								
HDSP-4206	Grey	–	2200	7000 Peak (1/5 df)	100 mA	2.6	100	Right
<b>GaP Green 571 nm</b> 								
HDSP-8606	Grey	–	680	1500	10	2.1	10	Right













# LED Indicators and Displays

## Through-hole Seven-Segment Displays—PCB Platform

Part Number	Face Color	Pin Configuration	Intensity ( $\mu\text{cd}$ )		Iv Test Current (mA)	Vf Typ. (V)	Vf Test Current (mA)	Decimal
			Min.	Typ.				
<b>7.62 mm (0.3") Single Digit Display</b>								
<b>GaP Red 620 nm</b> 								
HDSP-331E	Grey	Common Anode	800	1800	10	2.05	20	Right & Left
HDSP-333E	Grey	Common Cathode	800	1800	10	2.05	20	Right
HDSP-334E	Grey	Common Cathode	800	1800	10	2.05	20	Right
<b>GaP Green 573 nm</b> 								
HDSP-331G	Grey	Common Anode	800	2000	10	2.25	20	Right & Left
HDSP-333G	Grey	Common Cathode	800	2000	10	2.25	20	Right
HDSP-334G	Grey	Common Cathode	800	2000	10	2.25	20	Right
<b>AlGaAs Red 643 nm</b> 								
HDSP-331A	Grey	Common Anode	2001	4200	10	1.85	20	Right & Left
HDSP-333A	Grey	Common Cathode	2001	4200	10	1.85	20	Right
HDSP-334A	Grey	Common Cathode	2001	4200	10	1.85	20	Right
<b>GaP Yellow 590 nm</b> 								
HDSP-331Y	Grey	Common Anode	800	1500	10	2.15	20	Right & Left
HDSP-333Y	Grey	Common Cathode	800	1500	10	2.15	20	Right
HDSP-334Y	Grey	Common Cathode	800	1500	10	2.15	20	Right
<b>10 mm (0.4") Slim Font Single Digit Display</b>								
<b>GaP Red 625 nm</b> 								
HDSP-301E	Grey	Common Anode	1251	2000	10	1.90	20	Right
HDSP-303E	Grey	Common Cathode	1251	2000	10	1.90	20	Right
<b>GaP Green 573 nm</b> 								
HDSP-301G	Grey	Common Anode	2001	3200	10	2.25	20	Right
HDSP-303G	Grey	Common Cathode	2001	3200	10	2.25	20	Right
<b>AlGaAs Red 643 nm</b> 								
HDSP-301A	Grey	Common Anode	320	505	1	1.80	20	Right
HDSP-303A	Grey	Common Cathode	320	505	1	1.80	20	Right
<b>GaP Yellow 590 nm</b> 								
HDSP-301Y	Grey	Common Anode	1251	2000	10	2.15	20	Right
HDSP-303Y	Grey	Common Cathode	1251	2000	10	2.15	20	Right











# LED Indicators and Displays

## Through-hole Seven-Segment Displays—PCB Platform

Part Number	Face Color	Pin Configuration	Intensity ( $\mu\text{cd}$ )		I <sub>v</sub> Test Current (mA)	V <sub>f</sub> Typ. (V)	V <sub>f</sub> Test Current (mA)	Decimal
			Min.	Typ.				
<b>10.16 mm (0.4") Single Digit Display</b>								
<b>GaP Red 620 nm</b> 								
HDSP-311E	Grey	Common Anode	1250	3200	10	2.05	20	Right
HDSP-313E	Grey	Common Cathode	1250	3200	10	2.05	20	Right
<b>GaP Green 573 nm</b> 								
HDSP-311G	Grey	Common Anode	1250	3200	10	2.25	20	Right
HDSP-313G	Grey	Common Cathode	1250	3200	10	2.25	20	Right
<b>AlGaAs Red 643 nm</b> 								
HDSP-311A	Grey	Common Anode	3200	7500	10	1.85	20	Right
HDSP-313A	Grey	Common Cathode	3200	7500	10	1.85	20	Right
<b>GaP Yellow 590 nm</b> 								
HDSP-311Y	Grey	Common Anode	800	1500	10	2.15	20	Right
HDSP-313Y	Grey	Common Cathode	800	1500	10	2.15	20	Right
<b>10.16 mm (0.4") Dual Digit Display</b>								
<b>GaP Red 620 nm</b> 								
HDSP-G01E	Grey	Common Anode	1250	2600	10	2.05	20	–
HDSP-G03E	Grey	Common Cathode	1250	2600	10	2.05	20	–
<b>GaP Green 573 nm</b> 								
HDSP-G01G	Grey	Common Anode	1250	3200	10	2.25	20	–
HDSP-G03G	Grey	Common Cathode	1250	3200	10	2.25	20	–
<b>AlGaAs Red 643nm</b> 								
HDSP-G01A	Grey	Common Anode	3200	6500	10	1.85	20	–
HDSP-G03A	Grey	Common Cathode	3200	6500	10	1.85	20	–
<b>GaP Yellow 590 nm</b> 								
HDSP-G01Y	Grey	Common Anode	800	1500	10	2.15	20	–
HDSP-G03Y	Grey	Common Cathode	800	1500	10	2.15	20	–
<b>13 mm (0.56") Slim Font Single Digit Display</b>								
<b>GaP Red 625 nm</b> 								
HDSP-561E	Grey	Common Anode	2001	3526	10	1.90	20	Right
HDSP-563E	Grey	Common Cathode	2001	3526	10	1.90	20	Right
<b>GaP Green 573 nm</b> 								
HDSP-561G	Grey	Common Anode	3201	5601	10	2.25	20	Right
HDSP-563G	Grey	Common Cathode	3201	5601	10	2.25	20	Right
<b>AlGaAs Red 643 nm</b> 								
HDSP-561A	Grey	Common Anode	1010	2800	10	2.1	20	Right
HDSP-563A	Grey	Common Cathode	1010	2800	10	2.1	20	Right
<b>GaP Yellow 590 nm</b> 								
HDSP-561Y	Grey	Common Anode	506	878	1	1.80	20	Right
HDSP-563Y	Grey	Common Cathode	506	878	1	1.80	20	Right









# LED Indicators and Displays

## Through-hole Seven-Segment Displays—PCB Platform

Part Number	Face Color	Pin Configuration	Intensity ( $\mu\text{cd}$ )		Iv Test Current (mA)	Vf Typ. (V)	Vf Test Current (mA)	Decimal
			Min.	Typ.				
<b>14.2 mm (0.56") Single Digit Displays</b>								
<b>Blue 466 nm</b> 								
HDSP-501B	Grey	Common Anode	2020	3400	10	3.8	20	Right
HDSP-503B	Grey	Common Cathode	2020	3400	10	3.8	20	Right
<b>14.22 mm (0.56") Single Digit Display</b>								
<b>GaP Red 620 nm</b> 								
HDSP-511E	Grey	Common Anode	2001	4100	10	2.05	20	Right
HDSP-513E	Grey	Common Cathode	2001	4100	10	2.05	20	Right
<b>GaP Green 573 nm</b> 								
HDSP-511G	Grey	Common Anode	2001	4100	10	2.25	20	Right
HDSP-513G	Grey	Common Cathode	2001	4100	10	2.25	20	Right
<b>AlGaAs Red 643 nm</b> 								
HDSP-511A	Grey	Common Anode	3201	6500	10	1.85	20	Right
HDSP-513A	Grey	Common Cathode	3201	6500	10	1.85	20	Right
<b>GaP Yellow 590 nm</b> 								
HDSP-511Y	Grey	Common Anode	1251	2600	10	2.15	20	Right
HDSP-513Y	Grey	Common Cathode	1251	2600	10	2.15	20	Right
<b>14.2 mm (0.56") Dual Digit Displays</b>								
<b>GaP Yellow 587 nm</b> 								
HDSP-521Y	Grey	Common Anode	680	1800	10	2.1	20	Right
HDSP-523Y	Grey	Common Cathode	680	1800	10	2.1	20	Right
<b>GaP Red 626 nm</b> 								
HDSP-521E	Grey	Common Anode	1010	2800	10	2.1	20	Right
HDSP-523E	Grey	Common Cathode	1010	2800	10	2.1	20	Right
<b>GaP Green 571 nm</b> 								
HDSP-521G	Grey	Common Anode	1010	2500	10	2.1	10	Right
HDSP-523G	Grey	Common Cathode	1010	2500	10	2.1	10	Right
<b>AlGaAs Red 643 nm</b> 								
HDSP-521A	Grey	Common Anode	3201	6500	10	1.85	20	Right
HDSP-523A	Grey	Common Cathode	3201	6500	10	1.85	20	Right
<b>20 mm (0.8") Single Digit Display</b>								
<b>GaP Red 626 nm</b> 								
HDSP-815E	Grey	Common Anode	2300	4800	20	2.1	20	Right
HDSP-816E	Grey	Common Cathode	2300	4800	20	2.1	20	Right
<b>GaP Green 571 nm</b> 								
HDSP-815G	Grey	Common Anode	1500	3300	20	2.1	20	Right
HDSP-816G	Grey	Common Cathode	1500	3300	20	2.1	20	Right













# LED Indicators and Displays

## Surface Mount Seven-Segment Displays—PCB Platform

Part Number	Face Color	Pin Configuration	Intensity (mcd)		Iv Test Current (mA)	Vf Typ. (V)	Vf Test Current (mA)	Decimal
			Min.	Typ.				
<b>7.0mm (0.28") Single Digit SMT Display</b>								
<b>AllnGaP Red 624 nm</b> 								
HDSM-281C	Grey	Common Anode	3.4	7.5	10	2	20	Upper and Lower
HDSM-283C	Grey	Common Cathode	3.4	7.5	10	2	20	Upper and Lower
<b>AllnGaP Green 571 nm</b> 								
HDSM-281H	Grey	Common Anode	3.4	6	10	2.1	20	Upper and Lower
HDSM-283H	Grey	Common Cathode	3.4	6	10	2.1	20	Upper and Lower
<b>AllnGaP Yellow 589 nm</b> 								
HDSM-281F	Grey	Common Anode	3.4	8	10	2.1	20	Upper and Lower
HDSM-283F	Grey	Common Cathode	3.4	8	10	2.1	20	Upper and Lower
<b>AllnGaP Orange 605 nm</b> 								
HDSM-281L	Grey	Common Anode	3.4	8.5	10	2.1	20	Upper and Lower
HDSM-283L	Grey	Common Cathode	3.4	8.5	10	2.1	20	Upper and Lower
<b>7.0 mm (0.28") Dual Digit SMT Display</b>								
<b>AllnGaP Red 624 nm</b> 								
HDSM-291C	Grey	Common Anode	3.4	7.5	10	2	20	Upper and Lower
HDSM-293C	Grey	Common Cathode	3.4	7.5	10	2	20	Upper and Lower
<b>AllnGaP Green 571 nm</b> 								
HDSM-291H	Grey	Common Anode	3.4	6	10	2.1	20	Upper and Lower
HDSM-293H	Grey	Common Cathode	3.4	6	10	2.1	20	Upper and Lower
<b>AllnGaP Yellow 589 nm</b> 								
HDSM-291F	Grey	Common Anode	3.4	8	10	2.1	20	Upper and Lower
HDSM-293F	Grey	Common Cathode	3.4	8	10	2.1	20	Upper and Lower
<b>AllnGaP Orange 605 nm</b> 								
HDSM-291L	Grey	Common Anode	3.4	8.5	10	2.1	20	Upper and Lower
HDSM-293L	Grey	Common Cathode	3.4	8.5	10	2.1	20	Upper and Lower

# LED Indicators and Displays

## Surface Mount Seven-Segment Displays—PCB Platform cont.

Part Number	Face Color	Pin Configuration	Intensity (mcd)		Iv Test Current (mA)	Vf Typ. (V)	Vf Test Current (mA)	Decimal
			Min.	Typ.				
<b>10 mm (0.39") Single Digit SMT Display</b>								
<b>AllnGaP Red 624 nm</b> 								
HDSM-431C	Grey	Common Anode	8.6	14.3	10	2	20	Right
HDSM-433H	Grey	Common Cathode	8.6	14.3	10	2	20	Right
<b>AllnGaP Green 571 nm</b> 								
HDSM-431H	Grey	Common Anode	5.4	9	10	2.1	20	Right
HDSM-433H	Grey	Common Cathode	5.4	9	10	2.1	20	Right
<b>AllnGaP Yellow 589 nm</b> 								
HDSM-431F	Grey	Common Anode	8.6	15	10	2.1	20	Right
HDSM-433F	Grey	Common Cathode	8.6	15	10	2.1	20	Right
<b>AllnGaP Orange 605 nm</b> 								
HDSM-431L	Grey	Common Anode	8.6	16	10	2.1	20	Right
HDSM-433L	Grey	Common Cathode	8.6	16	10	2.1	20	Right
<b>10 mm (0.39") Dual Digit SMT Display</b>								
<b>AllnGaP Red 624 nm</b> 								
HDSM-441C	Grey	Common Anode	8.6	14.3	10	2	20	Right
HDSM-443C	Grey	Common Cathode	8.6	14.3	10	2	20	Right
<b>AllnGaP Green 571 nm</b> 								
HDSM-441H	Grey	Common Anode	5.4	9	10	2.1	20	Right
HDSM-443H	Grey	Common Cathode	5.4	9	10	2.1	20	Right
<b>AllnGaP Yellow 589 nm</b> 								
HDSM-441F	Grey	Common Anode	8.6	15	10	2.1	20	Right
HDSM-443F	Grey	Common Cathode	8.6	15	10	2.1	20	Right
<b>AllnGaP Orange 605 nm</b> 								
HDSM-441L	Grey	Common Anode	8.6	16	10	2.1	20	Right
HDSM-443L	Grey	Common Cathode	8.6	16	10	2.1	20	Right
<b>14.22 mm (0.56") Single Digit SMT Display</b>								
<b>AllnGaP Red 624 nm</b> 								
HDSM-531C	Grey	Common Anode	9	16	10	2	20	Right
HDSM-533C	Grey	Common Cathode	9	16	10	2	20	Right
<b>AllnGaP Green 571 nm</b> 								
HDSM-531H	Grey	Common Anode	6	10.5	10	2.1	20	Right
HDSM-533H	Grey	Common Cathode	6	10.5	10	2.1	20	Right
<b>AllnGaP Yellow 589 nm</b> 								
HDSM-531F	Grey	Common Anode	9	20	10	2.1	20	Right
HDSM-533F	Grey	Common Cathode	9	20	10	2.1	20	Right
<b>AllnGaP Orange 605 nm</b> 								
HDSM-531L	Grey	Common Anode	9	19.5	10	2.1	20	Right
HDSM-533L	Grey	Common Cathode	9	19.5	10	2.1	20	Right

# LED Indicators and Displays

## Surface Mount Seven-Segment Displays

Part Number	Face Color	Pin Configuration	Intensity (mcd)		Iv Test Current (mA)	Vf Typ. (V)	Vf Test Current (mA)	Decimal
			Min.	Typ.				
<b>14.22mm (0.56") Dual Digit SMT Display</b>								
<b>AllnGaP Red 624 nm</b>								
HDSM-541C	Grey	Common Anode	9	16	10	2	20	Right
HDSM-543C	Grey	Common Cathode	9	16	10	2	20	Right
<b>AllnGaP Green 571 nm</b>								
HDSM-541H	Grey	Common Anode	6	10.5	10	2.1	20	Right
HDSM-543H	Grey	Common Cathode	6	10.5	10	2.1	20	Right
<b>AllnGaP Yellow 589 nm</b>								
HDSM-541F	Grey	Common Anode	9	20	10	2.1	20	Right
HDSM-543F	Grey	Common Cathode	9	20	10	2.1	20	Right
<b>AllnGaP Orange 605 nm</b>								
HDSM-541L	Grey	Common Anode	9	19.5	10	2.1	20	Right
HDSM-543L	Grey	Common Cathode	9	19.5	10	2.1	20	Right

## Through-hole Seven-Segment Displays—PCB Platform Luminous Intensity Categories (Typ.)

### 7.62 mm (0.3") Single Digit

Bin ID	Customer Iv in mcd	
	Min.	Max.
<b>GaP Red</b>		
<b>HDSP-33xE</b>		
G	0.801	1.250
H	1.251	2.000
I	2.001	3.200
<b>GaP Green</b>		
<b>HDSP-33xG</b>		
G	0.801	1.250
H	1.251	2.000
I	2.001	3.200
<b>AlGaAs Red</b>		
<b>HDSP-33xA</b>		
I	2.001	3.200
J	3.201	5.050
K	5.051	8.000
<b>GaP Yellow</b>		
<b>HDSP-33xY</b>		
G	0.801	1.250
H	1.251	2.000
I	2.001	3.200

### 10 mm (0.4") Slim Font Single Digit

Bin ID	Customer Iv in mcd	
	Min.	Max.
<b>GaP Red</b>		
<b>HDSP-30xE</b>		
I	1.100	2.200
K	1.800	3.600
<b>GaP Green</b>		
<b>HDSP-30xG</b>		
K	1.800	3.600
L	2.800	5.600
<b>AlGaAs Red</b>		
<b>HDSP-30xA</b>		
F	0.280	0.560
G	0.450	0.900
<b>GaP Yellow</b>		
<b>HDSP-30xY</b>		
I	1.100	2.200
K	1.800	3.600





### 10.16 mm (0.4") Single Digit

Bin ID	Customer Iv in mcd	
	Min.	Max.
<b>GaP Red</b>		
<b>HDSP-31xE</b>		
H	1.251	2.000
I	2.001	3.200
J	3.201	5.050
<b>GaP Green</b>		
<b>HDSP-31xG</b>		
H	1.251	2.000
I	2.001	3.200
J	3.201	5.050
<b>AlGaAs Red</b>		
<b>HDSP-31xA</b>		
J	3.201	5.050
K	5.051	8.000
L	8.001	12.650
<b>GaP Yellow</b>		
<b>HDSP-31xY</b>		
G	0.801	1.250
H	1.251	2.000
I	2.001	3.200





# LED Indicators and Displays

Through-hole Seven-Segment Displays—PCB Platform  
Luminous Intensity Categories (Typ.)

## 10.16 mm (0.4"D) Dual Digit

Bin ID	Customer Iv in mcd	
	Min.	Max.
<b>GaP Red</b>  HDSP-G0xE		
H	1.251	2.000
I	2.001	3.200
J	3.201	5.050
<b>GaP Green</b>  HDSP-G0xG		
H	1.251	2.000
I	2.001	3.200
J	3.201	5.050
<b>AlGaAs Red</b>  HDSP-G0xA		
J	3.201	5.050
K	5.051	8.000
L	8.001	12.650
<b>GaP Yellow</b>  HDSP-G0xY		
G	0.801	1.250
H	1.251	2.000
I	2.001	3.200





## 13 mm (0.56") Slim Font Single Digit

Bin ID	Customer Iv in mcd	
	Min.	Max.
<b>GaP Red</b>  HDSP-56xE		
I	1.100	2.200
K	1.800	3.600
<b>GaP Green</b>  HDSP-56xG		
K	1.800	3.600
L	2.800	5.600
<b>AlGaAs Red</b>  HDSP-56xA		
F	0.280	0.560
G	0.450	0.900
<b>GaP Yellow</b>  HDSP-56xY		
I	1.100	2.200
K	1.800	3.600





## 0.56" Single Digit

Bin ID	Customer Iv in mcd	
	Min.	Max.
<b>Blue</b>  HDSP-50xB		
H	2.02	2.63
I	2.63	3.42
J	3.42	4.20
K	4.20	5.04



## 14.22 mm (0.56") Single Digit

Bin ID	Customer Iv in mcd	
	Min.	Max.
<b>GaP Red</b>  HDSP-51xE		
I	2.001	3.200
J	3.201	5.050
K	5.051	8.000
<b>GaP Green</b>  HDSP-51xG		
I	2.001	3.200
J	3.201	5.050
K	5.051	8.000
<b>AlGaAs Red</b>  HDSP-51xA		
J	3.201	5.050
K	5.051	8.000
L	8.001	12.650
<b>GaP Yellow</b>  HDSP-51xY		
H	1.251	2.000
I	2.001	3.200
J	3.201	5.050

## 0.56" Dual Digit

Bin ID	Customer Iv in mcd	
	Min.	Max.
<b>GaP Red</b>  HDSP-52xE		
G	2.28	3.42
H	3.42	5.13
I	5.13	7.69
<b>GaP Yellow</b>  HDSP-52xY		
F	1.52	2.28
G	2.28	3.42
H	3.42	5.13
<b>GaP Green</b>  HDSP-52xG		
G	2.28	3.42
H	3.42	5.13
<b>AlGaAs Red</b>  HDSP-52xA		
J	3.201	5.050
K	5.051	8.000
L	8.001	12.650

## 0.8" Single Digit

Bin ID	Customer Iv in mcd	
	Min.	Max.
<b>GaP Red</b>  HDSP-81xE		
N	4.78	8.34
P	6.82	11.86
Q	9.7	16.61
<b>GaP Green</b>  HDSP-81xG		
P	6.82	11.86
Q	9.7	16.61
R	13.6	23.74

# LED Indicators and Displays

## Through-hole Seven-Segment Displays—Leadframe Platform

### 7.6 mm (0.3") Micro Bright Displays Package Dimension

Part Number		
HDSP-	A151	A211
	7501	A213
	A401	A511
	A411	A513
	7401	
	7801	
	A153	
	7503	
	A403	
	A413	
	7403	
	7803	

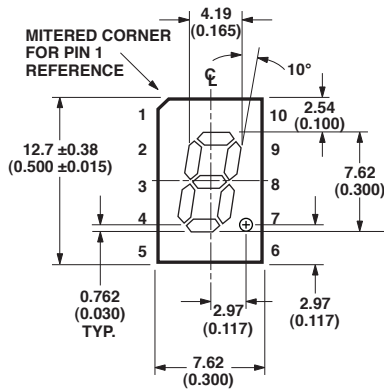

### 7.6 mm (0.3") Micro Bright Overflow Displays (Right Decimal Point) Package Dimension

Part Number	
HDSP-	7507
	A407
	7407
	7807
	7508
	A408
	7408
	7808

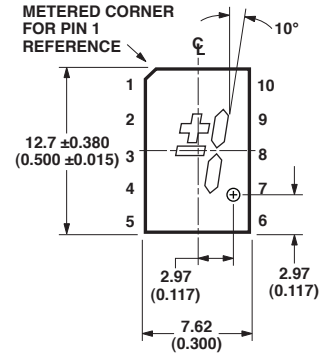

### 7.6 mm (0.3") Micro Bright Low Current Displays (Right Decimal Point) Package Dimension

Part Number		
HDSP-	A101	A111
	7511	A113
	A801	
	A901	
	A103	
	A803	
	A903	

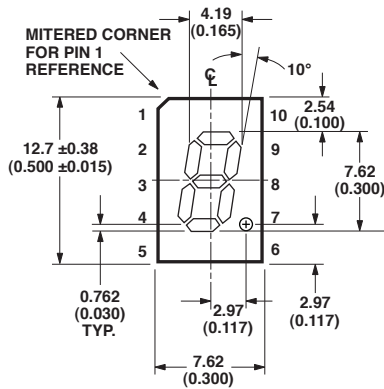

### 7.6 mm (0.3") Single Digit Displays Package Dimension

Part Number	
5802-	7610
	7611
	7613
	7620
	7621
	7623
	3600
	3601
	3603

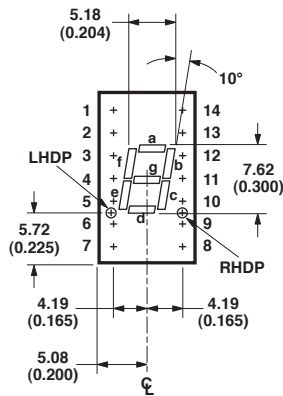

### 7.6 mm (0.3") Overflow Displays Package Dimension

Part Number	
5802-	7616
	7626
	3606

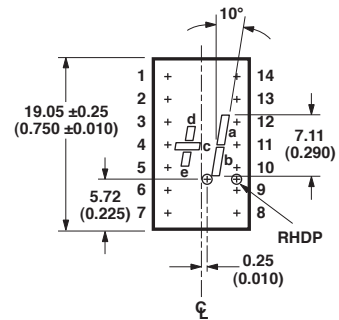

DIMENSIONS ARE IN MILLIMETERS (INCHES)

# LED Indicators and Displays

## Through-hole Seven-Segment Displays—Leadframe Platform

### 8 mm (0.31") Micro Bright Displays Package Dimension

Part Number	
HDSP-	Uxxx

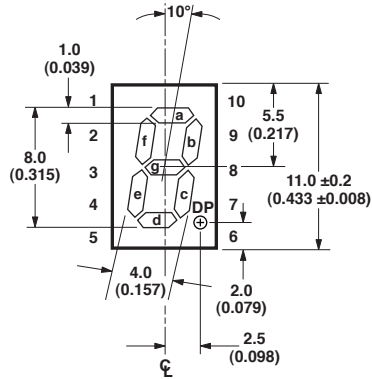

### 10 mm (0.4") Single Digit Displays (Right Decimal Point) Package Dimension

Part Number		
HDSP-	F111	F113
	F211	F213
	F511	F513
	F101	F103
	F201	F203
	F401	F403
	F411	F413
	F301	F303
	F501	F503
	F511	F513

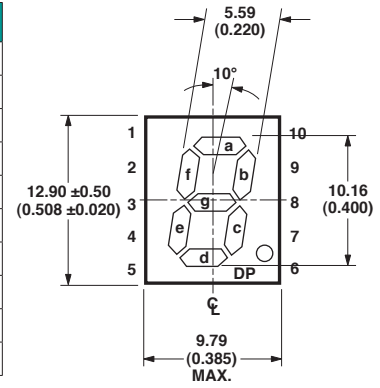

### 10 mm (0.4") Overflow Displays (Right Decimal Point) Package Dimension

Part Number		
HDSP-	F107	F108
	F207	F208
	F407	F408
	F307	F308
	F507	F508

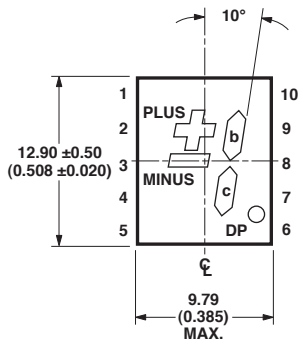

DIMENSIONS ARE IN MILLIMETERS (INCHES)

### 10 mm (0.4") Dual Digit Displays (Right Decimal Point) Package Dimension

Part Number		
HDSP-	G101	G103
	G111	G113
	G201	G203
	G211	G213
	G301	G303
	G401	G403
	G411	G413
	G501	G503
	G511	G513

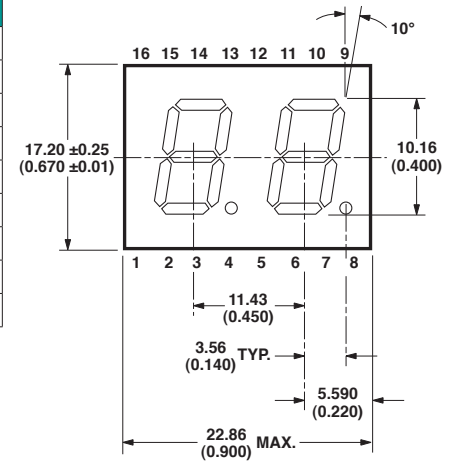

# LED Indicators and Displays

## Through-hole Seven-Segment Displays—Leadframe Platform

### 10.9 mm (0.43") Single Digit Displays (Right Decimal Point) Package Dimension

Part Number		
HDSP-	E101	E103
	3351	3353
5082-	7651	7653
	7661	7663
	4601	4603

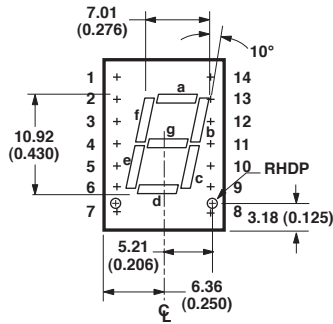

Part Number	
5802-	7650
	7660
	4600

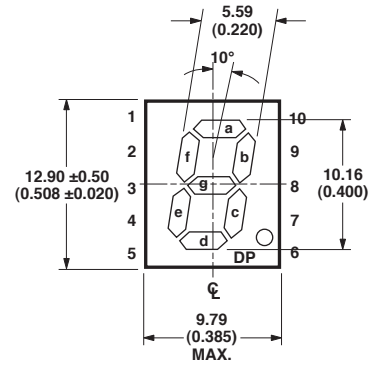

### 10.9 mm (0.43") Single Digit Displays Package Dimension

Part Number	
HDSP-	3350

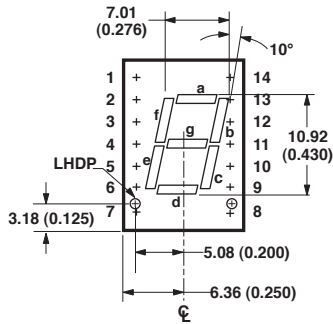

### 10.9 mm (0.43") Dual Digit Displays Package Dimension

Part Number		
HDSP-	G101	G103
	G201	G203
	G301	G303
	G401	G403
	G501	G503

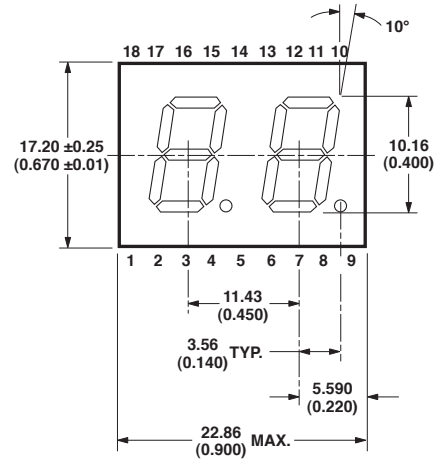

### 10.9 mm (0.43") Overflow Displays Package Dimension

Part Number		
HDSP-	4606	
	5082-	7656
		7666

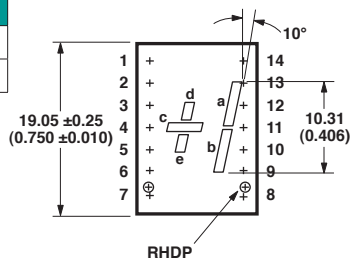

Part Number		
HDSP-	E106	3356

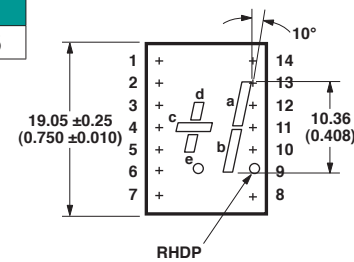

DIMENSIONS ARE IN MILLIMETERS (INCHES)

# LED Indicators and Displays

## Through-hole Seven-Segment Displays—Leadframe Platform

### 13 mm (0.56") Slim Font Displays Package Dimension

Part Number		
HDSP-	515H	516H
	515E	516E
	515L	516L
	515Y	516Y
	515G	516G
	56xE	56xG
	56xA	56xY

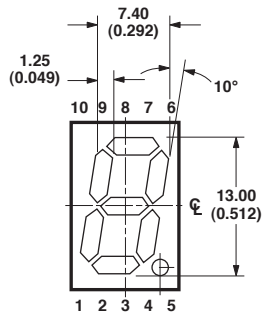

### 14.2 mm (0.56") Single Digit Displays (Right Decimal Point) Package Dimension

Part Number		
HDSP-	H111	H211
	H411	H511
	H113	H213
	H413	H513
	H101	H103
	H401	H403
	5551	5553
	5501	5503
	5701	5703
	5601	5603

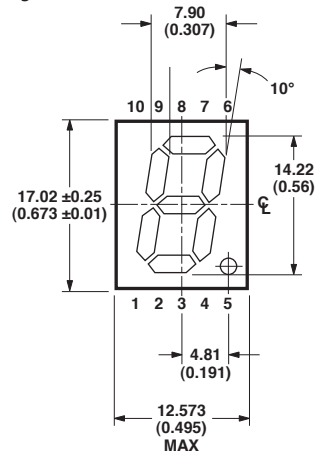

### 14.2 mm (0.56") Overflow Displays (Right Decimal Point) Package Dimension

Part Number		
HDSP-	H107	H108
	H407	H408
	5557	5558
	5507	5508
	5707	5708
	5607	5608

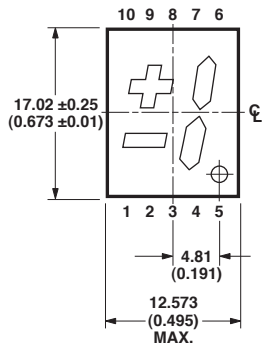

### 14.22 mm (0.56") Single Digit Displays Package Dimension

Part Number		
HDSP-	51xE	51xG
	51xA	51xY

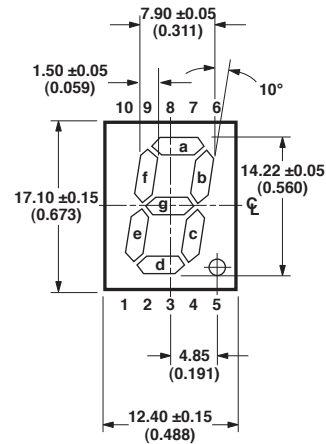

### 20 mm (0.8") Single Digit Overflow Displays Package Dimension

Part Number		
HDSP-	N106	N406
	3906	4206
	8606	

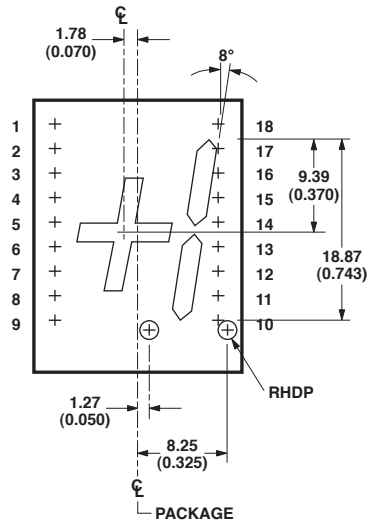

DIMENSIONS ARE IN MILLIMETERS (INCHES)

# LED Indicators and Displays

## Through-hole Seven-Segment Displays—Leadframe Platform cont.

### 20 mm (0.8") Single Digit Displays Package Dimension

Part Number		
HDSP-	3901	3903
	4201	4203
	8601	8603
	N101	N103
	N401	N403

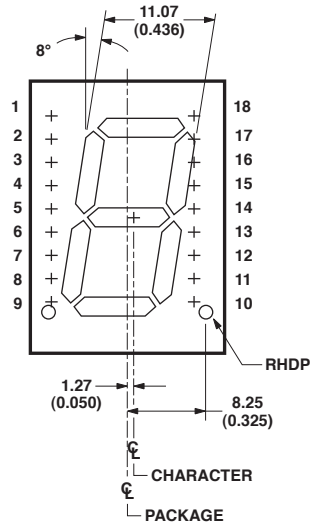

Part Number		
HDSP-	N100	N105
	3900	3905
	4200	4205
	8600	8605

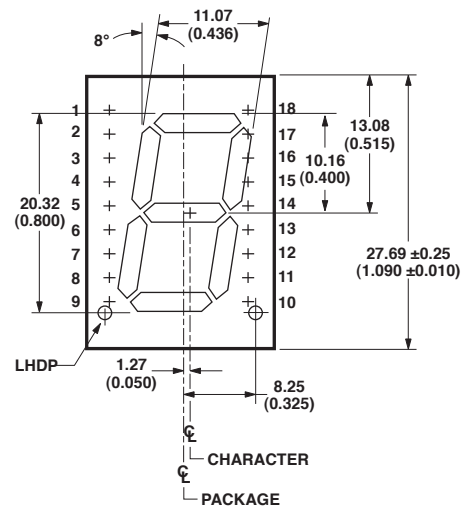

## Through-hole Seven Segment Displays—PCB Platform

### 7.62 mm (0.3") Single Digit Displays Package Dimension

Part Number		
HDSP-	331E	331A
	331G	331Y

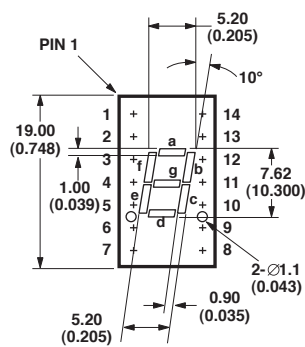

Part Number		
5802-	333E	334E
	333G	334G
	333A	334A
	333Y	334Y

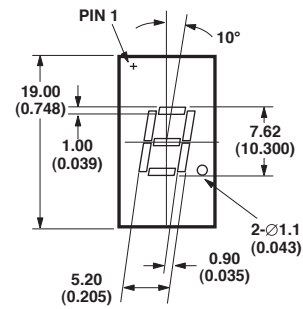

### 10 mm (0.4") Slim Font Single Digit Displays (Right Decimal Point) Package Dimension

Part Number		
HDSP-	315E	316E
	315L	316L
	315Y	316Y
	315G	316G
	30xE	30xG
	30xA	30xY

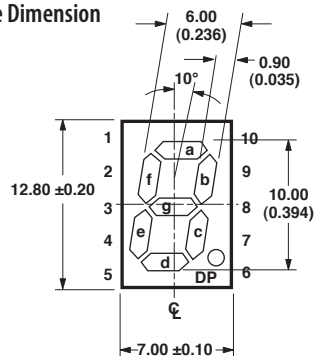

### 10.16 mm (0.4") Dual Digit Displays Package Dimension

Part Number		
HDSP-	G0xE	G0xG
	G0xA	G0xY

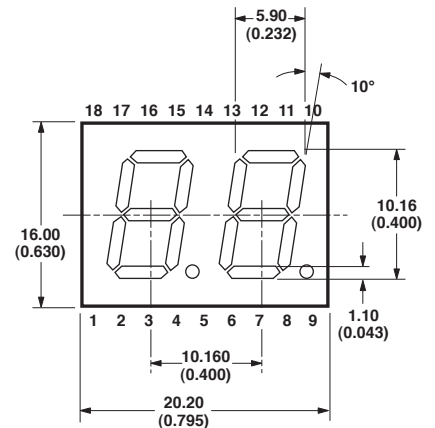

DIMENSIONS ARE IN MILLIMETERS (INCHES)

# LED Indicators and Displays

## Through-hole Seven Segment Displays—PCB Platform

### 10.16 mm (0.4") Single Digit Displays Package Dimension

Part Number	
HDSP-	311E
	311G
	311A
	311Y

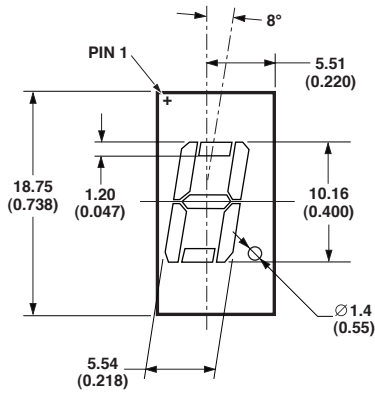

Part Number	
HDSP-	313E
	313G
	313A
	313Y

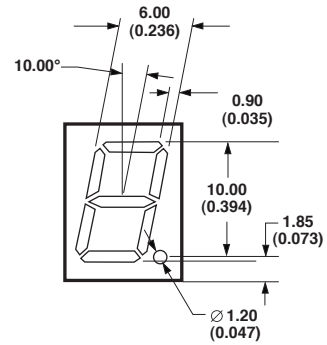

### 14.2 mm (0.56") Single Digit Displays (Right Decimal Point) Package Dimension

Part Number	
HDSP-	50xB

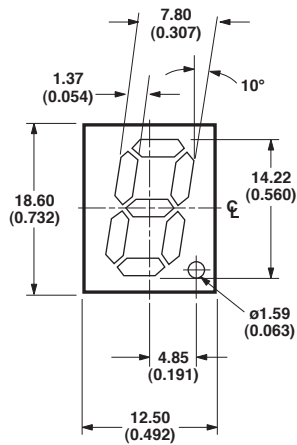

### 14.2 mm (0.56") Dual Digit Displays Package Dimension

Part Number			
HDSP-	52xA	52xE	
	52xG	52xY	

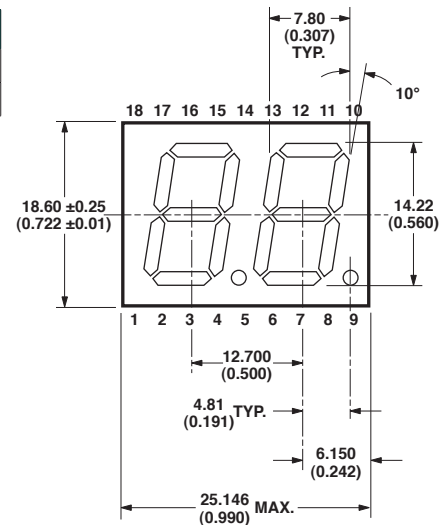

DIMENSIONS ARE IN MILLIMETERS (INCHES)

### 20 mm (0.8") Single Digit Displays Package Dimension

Part Number		
HDSP-	81xE	81xG

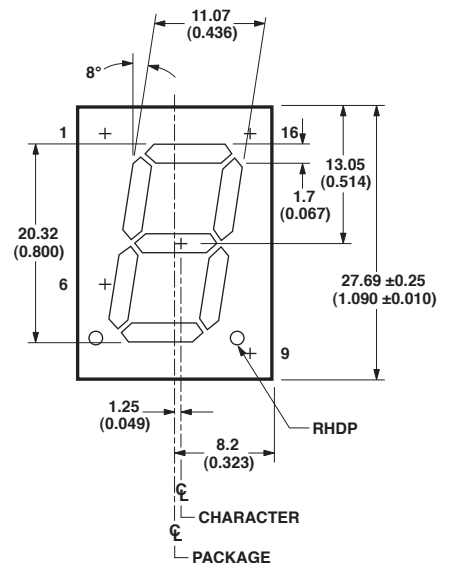

# LED Indicators and Displays

## Surface Mount Seven Segment Displays —PCB Platform

### 7.0mm (0.28") Single Digit SMT Display Package Dimension

Part Number	
HDSM-	281C
	283C
	281H
	283H
	281F
	283F
	281L
	283L

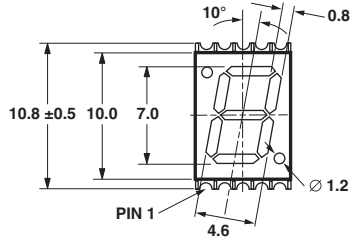

### 10.0mm (0.39") Dual Digit SMT Display Package Dimension

Part Number	
HDSM-	441C
	443C
	441H
	443H
	441F
	443F
	441L
	443L

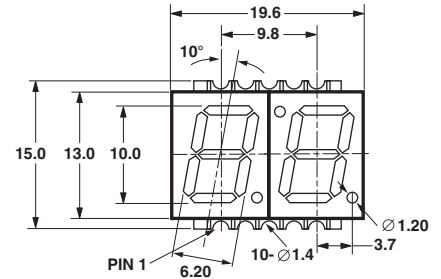

### 7.0mm (0.28") Dual Digit SMT Display Package Dimension

Part Number	
HDSM-	291C
	293C
	291H
	293H
	291F
	293F
	291L
	293L

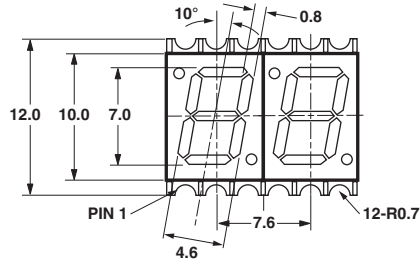

### 14.22mm (0.56") Single Digit SMT Display Package Dimension

Part Number	
HDSM	531C
	533C
	531H
	533H
	531F
	533F
	531L
	533L

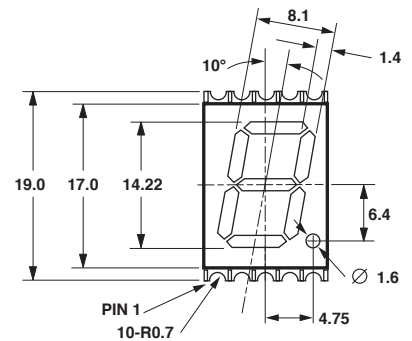

### 10mm (0.39") Single Digit SMT Display Package Dimension

Part Number	
HDSM	431C
	433C
	431H
	433H
	431F
	433F
	431L
	433L

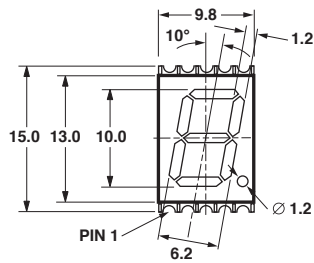

### 14.22mm (0.56") Dual Digit SMT Display Package Dimension

Part Number	
HDSM-	541C
	543C
	541H
	543H
	541F
	543F
	541L
	543L

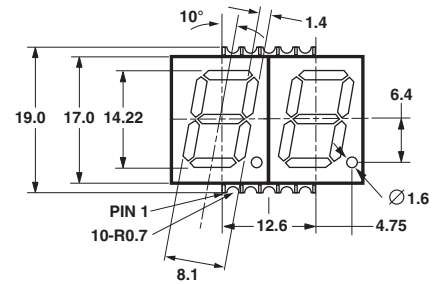

## Light Bars and Bar Graph Arrays

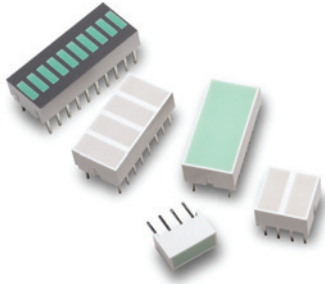

### Description — Light Bars

Light Bars are Avago Technologies' innovative solution to fixed message annunciation. They are used as annunciators that serve three customer functions: status indication, backlighting fixed messages and analog level indications (arrays). The Light Bars provide exceptional brightness at very low drive current for those applications where portability and battery backup are vital. These rectangular light sources are configured in single-in-line and dual-in-line packages that contain either single or segmented light emitting areas. They are also X-Y stackable.

### Features & Benefits

- Large, bright, uniform light emitting surface
- Yellow and green categorized for dominant wavelength
- Low heat dissipation
- Choices of colors — Red, Green, Yellow
- Various package sizes are X-Y stackable
- Industry standard SIP and DIP packages

### Typical Applications

- Business machines
  - Point of sale bar code scanner
  - Electronic typewriters
  - Fax machines
  - Electronic scales
  - Postal meters
- Instrumentation
  - Process control system
  - Medical equipment
  - Machine control systems
  - Meters and status indicators

- Telecommunications
  - PBX systems
  - Modems
  - Central switching systems
  - Diagnostic equipment
  - Short wave radios
- Transportation
  - Automotive dashboards
  - Truck and bus controls
  - Airport passenger metal detectors
  - Ticket vending machines
- Consumer
  - Appliance front panel
  - Hi-Fi/stereo equipment
  - Alarm system

### Description — 10-Element Bar Graph Arrays

Avago Technologies' 10-Element Bar Graph Arrays serve a market need for analog level indication. LED reliability, light emitting viewability make them suitable in place of mechanical meters. They are designed to display information in easily recognizable bar graph form. The packages are end stackable and are therefore capable of displaying long strings of information. The bar graph arrays are precision matched for both intensity and wavelength, saving you the time and trouble of matching individual parts. The prealigned bar graph elements locked in a single package eliminates the task of matching and aligning individual LEDs during manufacturing, along with the risk of visually substandard front panels resulting from misaligned indicators. Each device offers easy-to-handle packages that are compatible with standard DIP sockets.

### Features & Benefits

- Exclusive package interlock
  - Facilitate end stacking alignment
- Large segment size
  - Wide viewing angle
- Available in Red, Green, Yellow and multicolor
- Wide variety of applications
- Categorized and packaged for luminous intensity
  - Greater uniformity of light output
- Matched LEDs for uniform appearance

### Typical Applications

- Instrumentation
  - Meters
  - Channel indicators
  - Status indicators
- Process control
  - Level indicators
- Appliances
  - Status of indication
  - Mode of operation
- Transportation
  - Tachometers
  - Fuel gauges

- Consumer products
  - VU meters (stereos)
  - Radio channel scanners
  - Burglar alarms

# LED Indicators and Displays

## Light Bars

Shape	Size/# Light Emitting	Part Number	Color	Chip (nm) Typ.	Vf (V) Typ.	Vf (V) at If = mA	Iv at If = mA	Iv Min. (mcd)	Iv Typ. (mcd)	2 Intensity Bin Selection
0.4SIP	0.35" x 0.15" 1 area	HLCP-A100	AlGaAs Red	637	1.8	20	3	3	7.5	B, C
0.4SIP	0.35" x 0.15" 1 area	HLMP-2300	GaP Red	626	2	20	20	6	23	E, F
0.4SIP	0.35" x 0.15" 1 area	HLMP-2400	GaP Yellow	585	2.1	20	20	6	20	E, F
0.4SIP	0.35" x 0.15" 1 area	HLMP-2500	GaP Green	572	2.2	20	20	5	25	F, G
0.8SIP	0.75" x 0.15" 1 area	HLCP-B100	AlGaAs Red	637	1.8	20	3	6	15	B, C
0.8SIP	0.75" x 0.15" 1 area	HLMP-2350	GaP Red	626	2	20	20	13	45	E, F
0.8SIP	0.75" x 0.15" 1 area	HLMP-2450	GaP Yellow	585	2.1	20	20	13	38	E, F
0.8SIP	0.75" x 0.15" 1 area	HLMP-2550	GaP Green	572	2.2	20	20	11	50	F, G
0.4DIP	0.35" x 0.35" 1 area	HLCP-C100	AlGaAs Red	637	1.8	20	3	6	15	—
0.4DIP	0.35" x 0.35" 1 area	HLMP-2655	GaP Red	626	2	20	20	13	45	E, F
0.4DIP	0.35" x 0.35" 1 area	HLMP-2755	GaP Yellow	585	2.1	20	20	13	38	E, F
0.4DIP	0.35" x 0.35" 1 area	HLMP-2855	GaP Green	572	2.2	20	20	11	50	F, G
0.4DIP	0.35" x 0.15" 2 areas	HLCP-D100	AlGaAs Red	637	1.8	20	3	3	7.5	B, C
0.4DIP	0.35" x 0.15" 2 areas	HLMP-2600	GaP Red	626	2	20	20	6	23	E, F
0.4DIP	0.35" x 0.15" 2 areas	HLMP-2700	GaP Yellow	585	2.1	20	20	6	20	E, F
0.4DIP	0.35" x 0.15" 2 areas	HLMP-2800	GaP Green	572	2.1	20	20	5	25	—
0.8DIP	0.35" x 0.15" 4 areas	HLCP-E100	AlGaAs Red	637	1.8	20	3	3	7.5	B, C
0.8DIP	0.35" x 0.15" 4 areas	HLMP-2620	GaP Red	626	2	20	20	6	23	E, F
0.8DIP	0.35" x 0.15" 4 areas	HLMP-2720	GaP Yellow	585	2.1	20	20	6	20	E, F
0.8DIP	0.35" x 0.15" 4 areas	HLMP-2820	GaP Green	572	2.2	20	20	5	25	F, G
0.8DIP	0.15" x 0.75" 2 areas	HLCP-F100	AlGaAs Red	637	1.8	20	3	6	15	—
0.8DIP	0.15" x 0.75" 2 areas	HLMP-2635	GaP Red	626	2	20	20	13	45	—
0.8DIP	0.15" x 0.75" 2 areas	HLMP-2735	GaP Yellow	585	2.1	20	20	13	38	—
0.8DIP	0.15" x 0.75" 2 areas	HLMP-2835	GaP Green	572	2.2	20	20	11	50	—
0.8DIP	0.35" x 0.35" 2 areas	HLCP-G100	AlGaAs Red	637	1.8	20	3	6	15	—
0.8DIP	0.35" x 0.35" 2 areas	HLMP-2670	GaP Red	626	2	20	20	13	45	—
0.8DIP	0.35" x 0.35" 2 areas	HLMP-2770	GaP Yellow	585	2.1	20	20	13	38	—
0.8DIP	0.35" x 0.35" 2 areas	HLMP-2870	GaP Green	572	2.2	20	20	11	50	F, G
0.8DIP	0.35" x 0.75" 1 areas	HLCP-H100	AlGaAs Red	637	1.8	20	3	12	30	B, C
0.8DIP	0.35" x 0.75" 1 areas	HLMP-2685	GaP Red	626	2	20	20	22	80	—
0.8DIP	0.35" x 0.75" 1 areas	HLMP-2785	GaP Yellow	585	2.1	20	20	26	70	E, F
0.8DIP	0.35" x 0.75" 1 areas	HLMP-2885	GaP Green	572	2.2	20	20	22	100	F, G

# LED Indicators and Displays

## Bicolor Light Bars







Shape	Size/# Light Emitting	Part Number	Color	Chip (nm) Typ.	Vf (V) Typ.	Vf (V) at If = mA	Iv at If = mA	Iv Min. (mcd)	Iv Typ. (mcd)	2 Intensity Bin Selection
0.4DIP	0.35" x 0.35" 1 area	HLMP-2950	GaP Red	626	2	20	20	13	45	–
			GaP Yellow	585	2.1	20	20	13	38	–
0.4DIP	0.35" x 0.35" 1 area	HLMP-2965	GaP Red	626	2	20	20	19	45	–
			GaP Green	572	2.2	20	20	25	50	–



## Bar Graph Arrays

10 Element	HLCP-J100	AlGaAs Red	637	1.6	1	1	600	1000	–
	HDSP-4830	GaP Red	626	2.1	20	10	900	3500	G, H
	HDSP-4840	GaP Yellow	585	2.2	20	10	600	1900	F, G
	HDSP-4850	GaP Green	572	2.1	10	10	600	1900	H, I
Multicolor LA	HDSP-4832	GaP Red	626	2.1	20	10	600	3500	–
		GaP Yellow	585	2.2	20	10	600	1900	–
		GaP Green	572	2.1	10	10	600	1900	–
	HDSP-4836	GaP Red	626	2.1	20	10	600	3500	–
		GaP Yellow	585	2.2	20	10	600	1900	–
		GaP Green	572	2.1	10	10	600	1900	–
		GaP Yellow	585	2.2	20	10	600	1900	–
		GaP Red	626	2.1	20	10	600	3500	–





## Luminous Intensity Categories

### LED Light Bars





Bin ID	Customer Iv in mcd	
	Min.	Max.
AlGaAs Red  HLCP-A100 / D100 / E100 GaP Red  HLMP-2300 / 2600 / 2620		
B	4.5	8.2
C	6.8	12.1
D	10.1	18.5
E	15.3	27.8
F	22.8	45.5
AlGaAs Red  HLCP-B100 / C100 / F100 / G100 GaP Red  HLMP-2350 / 2635 / 2655 / 2670		
B	9.0	16.0
C	13.1	24.0
D	19.7	36.1
E	29.6	54.2
F	44.9	88.8
AlGaAs Red  HLCP-H100 GaP Red  HLMP-2685		
B	18.0	27.1
C	22.0	40.8
D	33.3	61.1
E	50.0	91.8
F	75.1	150.0

Bin ID	Customer Iv in mcd	
	Min.	Max.
GaP Yellow  HLMP-2400 / 2700 / 2720		
E	13.8	25.3
F	20.7	41.4
HLMP-2450 / 2735 / 2755 / 2770		
E	27.0	50.0
F	40.5	81.0
HLMP-2785		
E	54.0	99.0
F	81.0	162.0
GaP Green  HLMP-2500 / 2800 / 2820		
F	18.9	37.8
G	30.6	61.2
HLMP-2550 / 2835 / 2855 / 2870		
F	38.1	76.2
G	61.6	123.2
HLMP-2885		
F	75.1	150.3
G	121.1	242.2

### Bicolor Light Bars

Bin ID	Customer Iv in mcd	
	Min.	Max.
HLMP-2950/GaP Red 		
D	17.00	31.00
E	25.40	46.50
F	38.10	76.20
GaP Yellow 		
D	18.00	33.00
E	27.00	50.00
F	40.50	81.00
HLMP-2965/GaP Red 		
F	44.90	88.80
G	71.90	143.80
GaP Green 		
F	38.10	76.20
G	61.60	123.20

### Bar Graph Arrays

Bin ID	Customer Iv in mcd	
	Min.	Max.
AlGaAs Red / HLCP-J100  GaP Red/GaP Yellow/GaP Green    HDSP-4830 / 4840 / 4850		
D	0.61	1.11
E	0.91	1.67
F	1.37	2.51
G	2.05	3.76
H	3.08	5.64
I	4.62	8.64

# LED Indicators and Displays

## LED Light Bar and Bar Graph Array Package Dimension Drawings

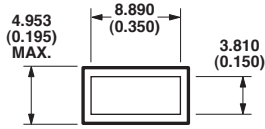

**HLCP-A100**  
HLMP-2300/2400/2500

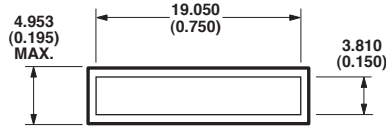

**HLCP-B100**  
HLMP-2x50

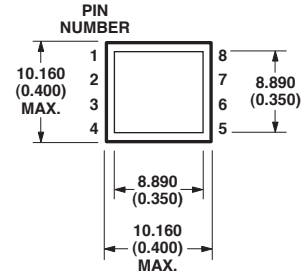

**HLCP-C100**  
HLMP-2x55

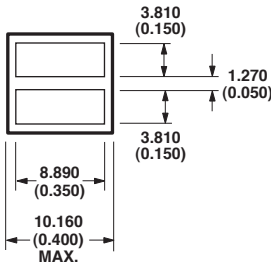

**HLCP-D100**  
HLMP-2600/2700/2800

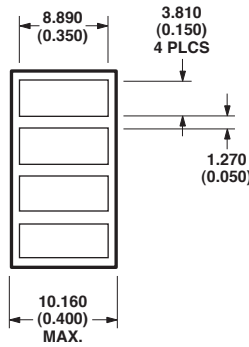

**HLCP-E100**  
HLMP-2x20

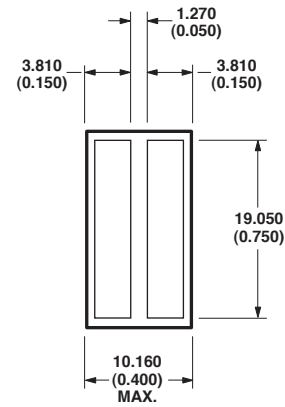

**HLCP-F100**  
HLMP-2x35

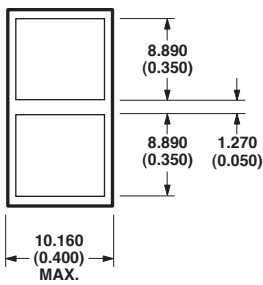

**HLCP-G100**  
HLMP-2x70

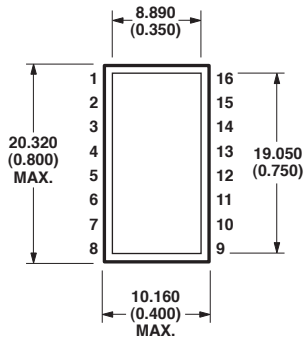

**HLCP-H100**  
HLMP-2x85

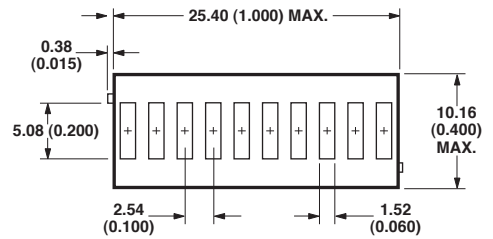

**HLCP-J100**  
HDSP-48x0

DIMENSIONS ARE IN MILLIMETERS (INCHES)

## Smart Displays

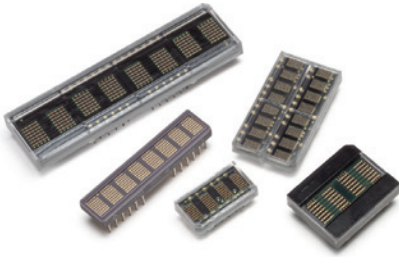

### Description

Avago Technologies offers high quality Smart Displays to meet a wide range of applications and requirements. The Smart Displays are available in both serial and parallel interface and have an ASIC driver that greatly simplifies design efforts. The Smart Displays are LED technology-based and are extremely reliable with a long life expectancy. They are resistant to extreme weather conditions, and to mechanical vibration and shock, making them suitable for industrial applications where maintenance resources are scarce. They are also suitable for the consumer market where the need for aesthetics and product differentiation provides a competitive advantage to our customers' end products. Avago Technologies' Smart Display products are positioned to support high volume and cost-effective solutions.

### Features and Benefits

- Robust design for high reliability, longer life and hot and cold temperature operating capability
  - Ideally suited for outdoor, industrial and automotive applications
- Alphanumeric characters and custom icons for messaging
  - Useful for conveying operating modes, status, warning and error codes
- Ability to flash or blink
  - Catch user's attention
- ASIC LED driver
  - Simplified design interfacing reduces design cycle time
- Emissive display with brightness control
  - Ability to modify brightness for subdued light environment and total darkness
- Aesthetically pleasing
  - Distinctive display allows product differentiation

### Typical Applications

- Industrial Equipment
  - Industrial ovens, reliability test equipment, analytical instruments, process control equipment, test and measuring instruments, temperature controllers, programmable logic controllers, security systems
- Networking
  - Telecommunication equipment, answering machines, telephones, base stations, PBX modems, network cards
- Outdoor Signs
  - Petrol pump meters
- Consumer
  - Audio/video equipment, audio mixers, set top boxes, amplifiers, musical instruments, gaming machines, currency/coin counters, security systems
- Consumer "White Goods"
  - Displays for washing machine digital panels, cookers, freezers and dishwashers
- Medical Equipment
  - Hospital monitoring systems
- Transportation
  - Displays, radar detectors, avionics displays
- Computers and Peripherals
  - CPU speed indicator, printer front panels, fax machines, copy machines, power supply equipment, cash registers

# LED Indicators and Displays

## Plastic Package, Serial Interface, 5 x 7 Dot Matrix Display with Custom Font Programmable

Part Number	Character	Color	Interface	Character Height (mm)	Intensity, Typ. ( $\mu\text{cd}$ )	Supply, Typ. (mA)
HCMS-2901	4	Yellow	Serial	3.7	64	132
HCMS-2902	4	Red	Serial	3.7	64	132
HCMS-2903	4	Green	Serial	3.7	114	132
HCMS-2904	4	Orange	Serial	3.7	64	132
HCMS-2905	4	AlGaAs Red	Serial	3.7	230	145
HCMS-2911	8	Yellow	Serial	3.7	64	264
HCMS-2912	8	Red	Serial	3.7	64	264
HCMS-2913	8	Green	Serial	3.7	114	264
HCMS-2914	8	Orange	Serial	3.7	64	264
HCMS-2915	8	AlGaAs Red	Serial	3.7	230	290
HCMS-2919	8	Blue	Serial	3.71	170	264
HCMS-2921	16	Yellow	Serial	3.7	64	528
HCMS-2922	16	Red	Serial	3.7	64	528
HCMS-2923	16	Green	Serial	3.7	114	528
HCMS-2924	16	Orange	Serial	3.7	64	528
HCMS-2925	16	AlGaAs Red	Serial	3.7	230	580
HCMS-2961	4	Yellow	Serial	4.6	64	132
HCMS-2962	4	Red	Serial	4.6	64	132
HCMS-2963	4	Green	Serial	4.6	114	132
HCMS-2964	4	Orange	Serial	4.6	64	132
HCMS-2965	4	AlGaAs Red	Serial	4.6	230	145
HCMS-2971	8	Yellow	Serial	4.6	64	264
HCMS-2972	8	Red	Serial	4.6	64	264
HCMS-2973	8	Green	Serial	4.6	114	264
HCMS-2974	8	Orange	Serial	4.6	64	264
HCMS-2975	8	AlGaAs Red	Serial	4.6	230	290
HCMS-2976	8	Blue	Serial	4.57	170	264
HCMS-3901	4	Yellow	Serial	3.71	148	132
HCMS-3902	4	Red	Serial	3.7	64	132
HCMS-3903	4	Green	Serial	3.71	252	132
HCMS-3904	4	Orange	Serial	3.7	64	132
HCMS-3906	4	Red	Serial	3.7	1150	132
HCMS-3907	4	Green	Serial	3.7	500	132
HCMS-3911	8	Yellow	Serial	3.71	148	264
HCMS-3912	8	Red	Serial	3.7	64	264
HCMS-3913	8	Green	Serial	3.71	252	264
HCMS-3914	8	Orange	Serial	3.7	64	264
HCMS-3916	8	Red	Serial	3.7	1150	264
HCMS-3917	8	Green	Serial	3.7	500	264
HCMS-3961	4	Yellow	Serial	4.57	148	132
HCMS-3962	4	Red	Serial	4.6	64	132
HCMS-3963	4	Green	Serial	4.57	252	132
HCMS-3964	4	Orange	Serial	4.6	64	132
HCMS-3966	4	Red	Serial	4.6	1150	132
HCMS-3967	4	Green	Serial	4.6	500	132
HCMS-3971	8	Yellow	Serial	4.57	148	264
HCMS-3972	8	Red	Serial	4.6	64	264
HCMS-3973	8	Green	Serial	4.57	252	264
HCMS-3974	8	Orange	Serial	4.6	64	264
HCMS-3976	8	Red	Serial	4.6	1150	264
HCMS-3977	8	Green	Serial	4.6	500	264

**Notes:**

Typical values at  $T_A = 25^\circ\text{C}$ .

Luminous intensity for one pixel at  $V_{LED} = 5.0\text{V}$ , 50% peak pixel current, 100% pulse width.

Supply current at  $V_{LED} = 5.0\text{V}$ , 100% peak pixel current, 100% pulse width, 20 pixels per digit at all digit locations.

# LED Indicators and Displays

## Plastic Package, Serial Interface, 5 x 7 Dot Matrix Display with Custom Font Programmable

Part Number	Character	Color	Interface	Character Height (mm)	Intensity, Typ. ( $\mu\text{cd}$ )	Supply, Typ. (mA)
HDLY-1414	4	Yellow	Parallel	3.6	3.7	110
HDLO-1414	4	Red	Parallel	3.6	3.5	110
HDLG-1414	4	Green	Parallel	3.6	5.6	110
HDLA-1414	4	Orange	Parallel	3.6	3.5	110
HDLU-1414	4	AlGaAs Red	Parallel	3.6	3.1	34
HDLS-1414	4	AlGaAs Red	Parallel	3.6	12.7	125
HDLY-2416	4	Yellow	Parallel	5.1	3.7	110
HDLO-2416	4	Red	Parallel	5.1	3.5	110
HDLG-2416	4	Green	Parallel	5.1	5.6	110
HDLA-2416	4	Orange	Parallel	5.1	3.5	110
HDLU-2416	4	AlGaAs Red	Parallel	5.1	3.1	34
HDLS-2416	4	AlGaAs Red	Parallel	5.1	12.7	125
HDLY-3416	4	Yellow	Parallel	6.9	3.7	110
HDLO-3416	4	Red	Parallel	6.9	3.5	110
HDLG-3416	4	Green	Parallel	6.9	5.6	110
HDLA-3416	4	Orange	Parallel	6.9	3.5	110

## Plastic Package, Parallel Interface, 8 Character, 5 x 7 Dot Matrix Display with 128 Character ASCII Decoder

Part Number	Character	Color	Interface	Character Height (mm)	Intensity, Typ. ( $\mu\text{cd}$ )	Supply, Typ. (mA)
HDSP-2530	8	Orange	Parallel	4.6	7.5	300
HDSP-2531	8	Yellow	Parallel	4.6	7.	300
HDSP-2532	8	Red	Parallel	4.6	7.5	300
HDSP-2533	8	Green	Parallel	4.6	7.5	300
HDSP-2534	8	AlGaAs Red	Parallel	4.6	15	330
HDSP-2110	8	Orange	Parallel	4.8	7.5	300
HDSP-2111	8	Yellow	Parallel	4.8	7.5	300
HDSP-2112	8	Red	Parallel	4.8	7.5	300
HDSP-2113	8	Green	Parallel	4.8	7.5	300
HDSP-2107	8	AlGaAs Red	Parallel	4.8	15	330
HDSP-2500	8	Orange	Parallel	7.0	7.5	300
HDSP-2501	8	Yellow	Parallel	7.0	7.5	300
HDSP-2502	8	Red	Parallel	7.0	7.5	300
HDSP-2503	8	Green	Parallel	7.0	7.5	300
HDSP-2504	8	AlGaAs Red	Parallel	7.0	1.5	330

**Notes:**

Typical values at  $V_{DD} = 5.0V$ ,  $T_A = 25^\circ\text{C}$ .

Luminous intensity at 100% full brightness, character average with “#” (20 pixels) displayed.

Supply current at 100% brightness, with all character locations displaying “#” (20 pixels).

# LED Indicators and Displays

## Glass/Ceramic Package, Parallel Interface, 8 Character, 5 x 7 Dot Matrix with 128 Character ASCII Decoder

Part Number	Character	Color	Interface	Character Height (mm)	Intensity, Typ. ( $\mu\text{cd}$ )	Supply, Typ. (mA)
HDSP-2131	8	Yellow	Parallel	4.8	7.5	300
HDSP-2132	8	Red	Parallel	4.8	7.5	300
HDSP-2133	8	Green	Parallel	4.8	7.5	300
HDSP-2179	8	Orange	Parallel	4.8	7.5	300

**Notes:**

Typical values at  $V_{DD} = 5.0V$ ,  $T_A = 25^\circ\text{C}$ .

Luminous intensity at 100% full brightness, character average with “#” (20 pixels) displayed.

Supply current at 100% brightness, with all character locations displaying “#” (20 pixels).

## Glass/Ceramic Package, 4 x 7 Hexadecimal Display with Built-in BCD Decoder/Driver

Part Number	Description/Decimal Point	Color	Operation Temperature ( $^\circ\text{C}$ )	Character Height (mm)	Luminous Intensity Typ. ( $\mu\text{cd}$ )	Supply Current Typ. (mA)
HDSP-0760	Numeric, RHDP	HER	-55 to 85	7.4	140	78
HDSP-0761	Numeric, LHDP	HER	-55 to 85	7.4	140	78
HDSP-0762	Hexadecimal	HER	-55 to 85	7.4	140	78
HDSP-0770	Numeric, RHDP	HER	-55 to 85	7.4	620	120
HDSP-0771	Numeric, LHDP	HER	-55 to 85	7.4	620	120
HDSP-0772	Hexadecimal	HER	-55 to 85	7.4	620	120
HDSP-0781	Numeric, RHDP	HER	-55 to 100	7.4	140	78
HDSP-0782	Numeric, LHDP	HER	-55 to 100	7.4	140	78
HDSP-0784	Hexadecimal	HER	-55 to 100	7.4	140	78
HDSP-0791	Numeric, RHDP	HER	-55 to 100	7.4	620	120
HDSP-0792	Numeric, LHDP	HER	-55 to 100	7.4	620	120
HDSP-0794	Hexadecimal	HER	-55 to 100	7.4	620	120
HDSP-0860	Numeric, RHDP	Yellow	-55 to 85	7.4	490	120
HDSP-0861	Numeric, LHDP	Yellow	-55 to 85	7.4	490	120
HDSP-0862	Hexadecimal	Yellow	-55 to 85	7.4	490	120
HDSP-0881	Numeric, RHDP	Yellow	-55 to 100	7.4	490	120
HDSP-0884	Hexadecimal	Yellow	-55 to 100	7.4	490	120
HDSP-0960	Numeric, RHDP	Green	-55 to 85	7.4	1100	120
HDSP-0961	Numeric, LHDP	Green	-55 to 85	7.4	1100	120
HDSP-0962	Hexadecimal	Green	-55 to 85	7.4	1100	120
HDSP-0981	Numeric, RHDP	Green	-55 to 100	7.4	1100	120
HDSP-0984	Hexadecimal	Green	-55 to 100	7.4	1100	120

**Notes:**

Typical values at  $V_{DD} = 5.0V$ ,  $T_A = 25^\circ\text{C}$ .

Luminous intensity per LED (Digit Average).

Supply current with “5” or “B” character displayed.

## Glass/Ceramic Package Over Range $\pm$ with Built-in BCD Decoder/Driver

Part Number	Description/Decimal Point	Color	Operation Temperature ( $^\circ\text{C}$ )	Character Height (mm)	Luminous Intensity Typ. ( $\mu\text{cd}$ )	Supply Current Typ. (mA)
HDSP-0763	Overrange $\pm 1$	HER	-55 to 85	7.4	140	11.2
HDSP-0863	Overrange $\pm 1$	Yellow	-55 to 85	7.4	490	32
HDSP-0963	Overrange $\pm 1$	Green	-55 to 85	7.4	1100	32

**Notes:**

Typical values at  $V_{DD} = 5.0V$ ,  $T_A = 25^\circ\text{C}$ .

Luminous intensity per LED (Digit Average).

# LED Indicators and Displays

## LED Dot Matrix Smart Displays Package Dimension Drawings

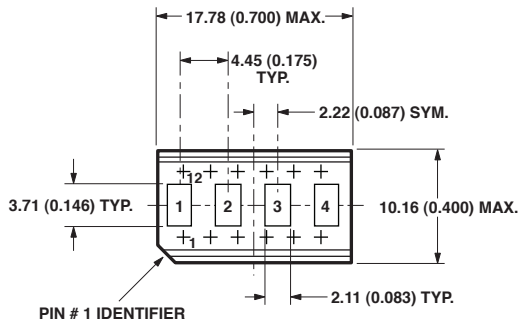

HCMS-290x/HCMS-390x

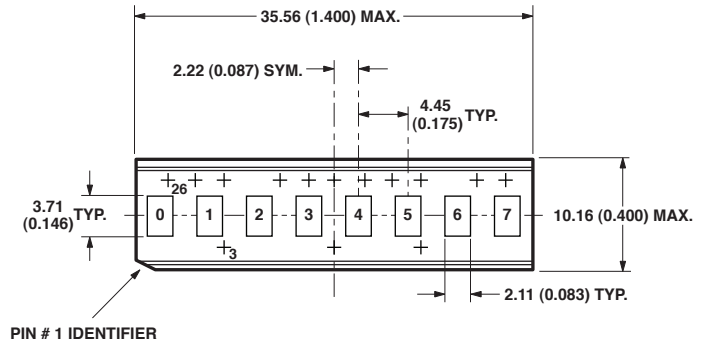

HCMS-291x/HCMS-391x

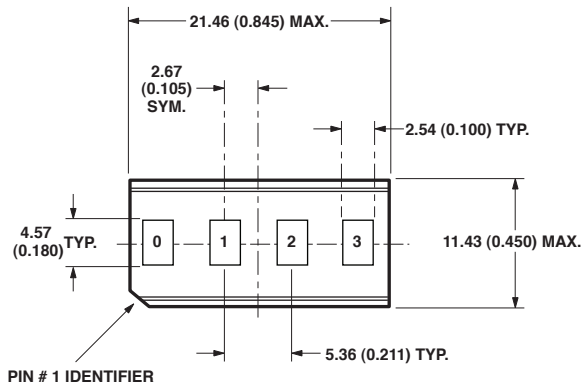

HCMS-296x/HCMS-396x

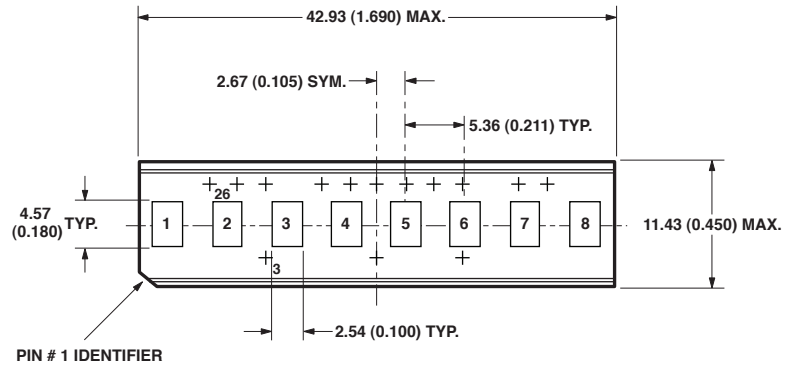

HCMS-297x/HCMS-397x

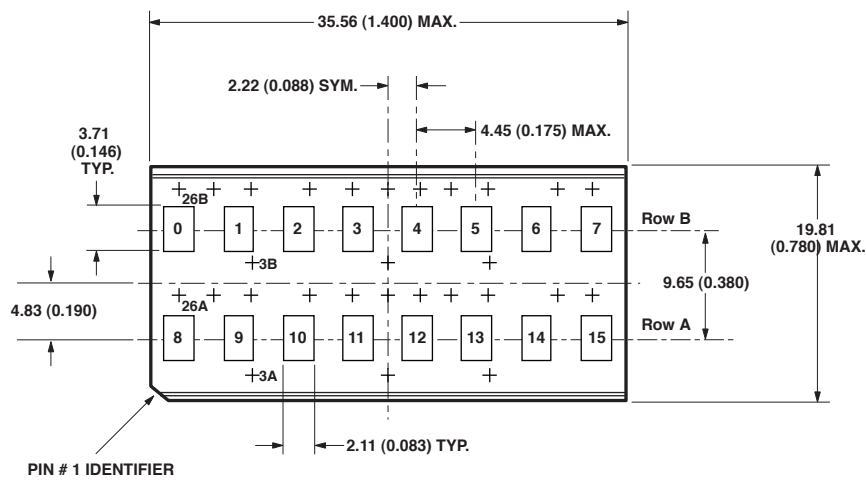

HCMS-292x

DIMENSIONS ARE IN MILLIMETERS (INCHES)

# LED Indicators and Displays

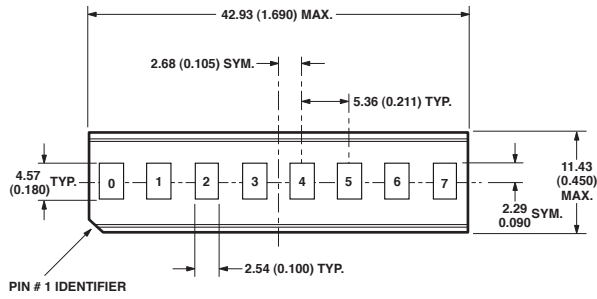

HDSP-253x

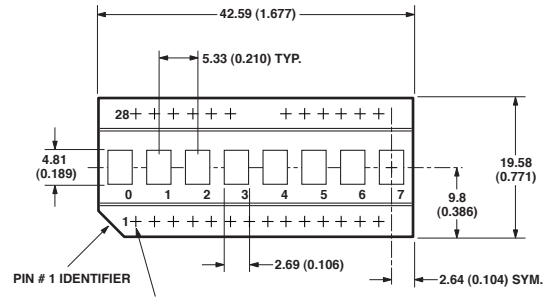

HDSP-2107, -211x

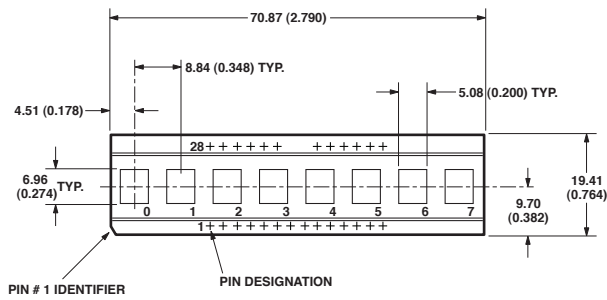

HDSP-250x

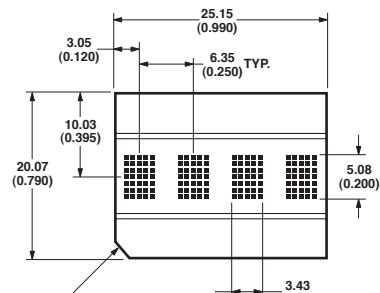

HDLx-2416

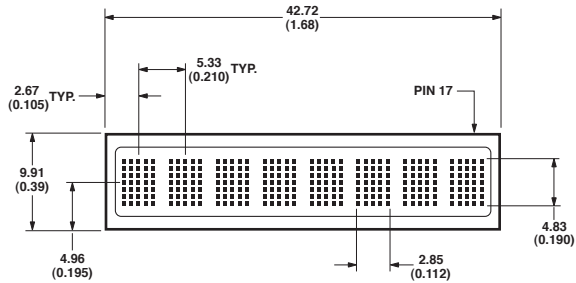

HDSP-213x, -2179

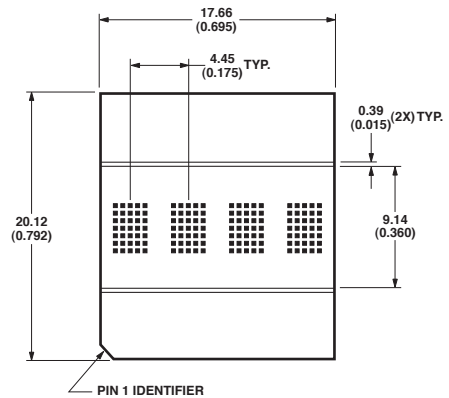

HDLx-1414

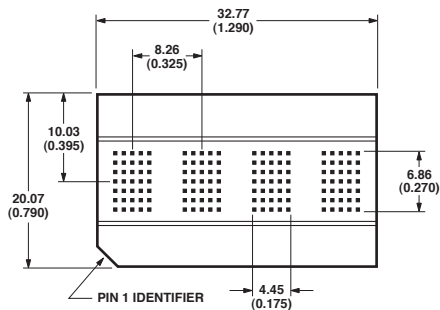

HDLx-3416

DIMENSIONS ARE IN MILLIMETERS (INCHES)

## About Avago Technologies

Avago Technologies is a leading supplier of analog interface components for communications, industrial and consumer applications. By leveraging its core competencies in III-V compound and silicon semiconductor design and processing, the company provides an extensive range of analog, mixed signal and optoelectronics components and subsystems to more than 40,000 customers. Backed by strong customer service support, the company's products serve four diverse end markets: industrial and automotive, wired infrastructure, wireless communications, and computer peripherals. Avago has a global employee presence and heritage of technical innovation dating back 40 years to its Hewlett-Packard roots. Information about Avago is available on the Web at [www.avagotech.com](http://www.avagotech.com)

---

For product information and a complete list of distributors,  
please go to our web site:

**[www.avagotech.com](http://www.avagotech.com)**  
**[www.avagotech.com/led](http://www.avagotech.com/led)**

For technical support please email a Technical Response Center in  
your region:

*United States:* [support@avagotech.com](mailto:support@avagotech.com)

*Europe:* [info@promotionteam.de](mailto:info@promotionteam.de)

*Asia Pacific:* [pacrim.components@avagotech.com](mailto:pacrim.components@avagotech.com)

Avago, Avago Technologies, and the A logo are trademarks of Avago Technologies in the United States and other countries.  
Data subject to change. Copyright © 2008 Avago Technologies Obsoletes AV00-0112EN  
AV00-0146EN 7/29/08

**AVAGO**  
TECHNOLOGIES